

MELSEC System Q

Programmable Logic Controllers

User's Manual

HART Analog Input Module ME1AD8HAI-Q



About this Manual

The texts, illustration, diagrams and examples in this manual are provided for information purposes only. They are intended as aids to help explain the installation, operation, programming and use of the programmable logic controllers of the MELSEC System Q.

If you have any questions about the installation and operation of any of the products described in this manual please contact your local sales office or distributor (see back cover). You can find the latest information and answers to frequently asked questions on our website at www.mitsubishi-automation.com.

MITSUBISHI ELECTRIC EUROPE BV reserves the right to make changes to this manual or the technical specifications of its products at any time without notice.

© 2009 –2013

**HART Analog Input Module
ME1AD8HAI-Q
User's Manual
Art.-no.: 229753**

Version			Changes / Additions / Corrections
A	10/2009	pdp-dk	First edition
B	03/2010	pdp-dk	<ul style="list-style-type: none"> • New section 3.5.25: HART device information refresh interval (Un\G191) • Addition of Un\G191 to buffer memory assignment in section 3.5.1
C	12/2010	pdp-dk	<ul style="list-style-type: none"> • Correction in section 3.2 (Specifications, accuracy): "digital output value" was changed to "digital output range"; "Photo coupler isolation" was changed to "Digital isolator insulation" • Correction in section 3.2.2 (Accuracy) • Correction in section 4.1: Subitem "A protective film is attached to the..." was removed – Modul has no protective film. • Correction in section 6.4: "..., the LED ON status..." in the first sentence was removed. • Correction on page 1-2 and corresponding on page 3-6: "...is output..." was changed to "...is triggered..." in 3 sentences.
D	02/2012	pdp-dk	<ul style="list-style-type: none"> • Correction on page 3-47: Meaning of the bits in buffer memory address 53 in Fig. 3-29
E	01/2013	pdp-dk	<ul style="list-style-type: none"> • New chapter 5: "Intelligent Function Utility (GX Works2)" • Addition of the "Intelligent function utility" in section 1.1 • Update of table 2-1 and the item "Supported software packages" in section 2.1 • Changes in section 2.2 • Note in table 3-8 (entry for X9) • Note regarding initial settings in Fig. 6-1

Safety Guidelines

For use by qualified staff only

This manual is only intended for use by properly trained and qualified electrical technicians who are fully acquainted with the relevant automation technology safety standards. All work with the hardware described, including system design, installation, configuration, maintenance, service and testing of the equipment, may only be performed by trained electrical technicians with approved qualifications who are fully acquainted with all the applicable automation technology safety standards and regulations. Any operations or modifications to the hardware and/or software of our products not specifically described in this manual may only be performed by authorised Mitsubishi Electric staff.

Proper use of the products

The programmable logic controllers of the MELSEC System Q are only intended for the specific applications explicitly described in this manual. All parameters and settings specified in this manual must be observed. The products described have all been designed, manufactured, tested and documented in strict compliance with the relevant safety standards. Unqualified modification of the hardware or software or failure to observe the warnings on the products and in this manual may result in serious personal injury and/or damage to property. Only peripherals and expansion equipment specifically recommended and approved by Mitsubishi Electric may be used with the programmable logic controllers of the MELSEC System Q.

All and any other uses or application of the products shall be deemed to be improper.

Relevant safety regulations

All safety and accident prevention regulations relevant to your specific application must be observed in the system design, installation, configuration, maintenance, servicing and testing of these products. The regulations listed below are particularly important in this regard. This list does not claim to be complete, however; you are responsible for being familiar with and conforming to the regulations applicable to you in your location.

- VDE Standards
 - VDE 0100
Regulations for the erection of power installations with rated voltages below 1000 V
 - VDE 0105
Operation of power installations
 - VDE 0113
Electrical installations with electronic equipment
 - VDE 0160
Electronic equipment for use in power installations
 - VDE 0550/0551
Regulations for transformers
 - VDE 0700
Safety of electrical appliances for household use and similar applications
 - VDE 0860
Safety regulations for mains-powered electronic appliances and their accessories for household use and similar applications.
- Fire safety regulations
- Accident prevention regulations
 - VBG Nr.4
Electrical systems and equipment

Safety warnings in this manual

In this manual warnings that are relevant for safety are identified as follows:



DANGER:

Failure to observe the safety warnings identified with this symbol can result in health and injury hazards for the user.



WARNING:

Failure to observe the safety warnings identified with this symbol can result in damage to the equipment or other property.

General safety information and precautions

The following safety precautions are intended as a general guideline for using PLC systems together with other equipment. These precautions must always be observed in the design, installation and operation of all control systems.



DANGER:

- **Observe all safety and accident prevention regulations applicable to your specific application. Always disconnect all power supplies before performing installation and wiring work or opening any of the assemblies, components and devices.**
- **Assemblies, components and devices must always be installed in a shockproof housing fitted with a proper cover and fuses or circuit breakers.**
- **Devices with a permanent connection to the mains power supply must be integrated in the building installations with an all-pole disconnection switch and a suitable fuse.**
- **Check power cables and lines connected to the equipment regularly for breaks and insulation damage. If cable damage is found immediately disconnect the equipment and the cables from the power supply and replace the defective cabling.**
- **Before using the equipment for the first time check that the power supply rating matches that of the local mains power.**
- **Take appropriate steps to ensure that cable damage or core breaks in the signal lines cannot cause undefined states in the equipment.**
- **You are responsible for taking the necessary precautions to ensure that programs interrupted by brownouts and power failures can be restarted properly and safely. In particular, you must ensure that dangerous conditions cannot occur under any circumstances, even for brief periods.**
- **EMERGENCY OFF facilities conforming to EN 60204/IEC 204 and VDE 0113 must remain fully operative at all times and in all PLC operating modes. The EMERGENCY OFF facility reset function must be designed so that it cannot ever cause an uncontrolled or undefined restart.**
- **You must implement both hardware and software safety precautions to prevent the possibility of undefined control system states caused by signal line cable or core breaks.**
- **When using modules always ensure that all electrical and mechanical specifications and requirements are observed exactly.**

Contents

1	Overview	
1.1	Features	1-1
2	System Configuration	
2.1	Applicable Systems.....	2-1
2.2	How to Check the Function Version and Serial No. of the Modules	2-3
3	Detailed Description of the Module	
3.1	Part Names.....	3-1
3.1.1	Signal Layout of the Terminal Block	3-2
3.2	Specifications	3-3
3.2.1	I/O conversion characteristic.....	3-4
3.2.2	Accuracy	3-4
3.2.3	External Dimensions	3-5
3.3	Functions of the HART Analog Input Module	3-6
3.3.1	A/D conversion methods	3-7
3.3.2	Maximum and minimum values hold function.....	3-9
3.3.3	Input signal error detection function	3-10
3.3.4	Warning output function	3-11
3.3.5	Scaling Function.....	3-15
3.3.6	HART Master Function	3-16
3.4	I/O Signals for the Programmable Controller CPU.....	3-18
3.4.1	List of I/O signals	3-18
3.4.2	Details of I/O signals	3-19
3.5	Buffer Memory	3-23
3.5.1	Buffer memory assignment	3-24
3.5.2	A/D conversion enable/disable setting (Un\G0).....	3-40
3.5.3	CHI Average time/Average number of times/Moving average/ Time constant settings (Un\G1 to Un\G8).....	3-40
3.5.4	A/D conversion completed flag (Un\G10).....	3-41
3.5.5	CHI digital output value (Un\G11 to Un\G18)	3-41
3.5.6	Write data error code (Un\G19).....	3-42

3.5.7	Setting range (Un\G20, Un\G21).....	3-42
3.5.8	Averaging process specification (Un\G24, Un\G25).....	3-43
3.5.9	CHI maximum value/minimum value storage area (Un\G30 to Un\G45)...	3-44
3.5.10	Input signal error detection setting (Un\G47)	3-44
3.5.11	Warning output settings (Un\G48)	3-45
3.5.12	Input signal error detection flag (Un\G49)	3-46
3.5.13	Warning output flag (Un\G50, Un\G51).....	3-47
3.5.14	Scaling enable/disable setting (Un\G53).....	3-47
3.5.15	CHI scaling value storage area (Un\G54 to Un\G61)	3-48
3.5.16	CHI scaling upper/lower limit value (Un\G62 to Un\G77)	3-48
3.5.17	CHI process alarm upper/lower limit value (Un\G86 to Un\G117)	3-48
3.5.18	CHI rate alarm warning detection period (Un\G118 to Un\G125)	3-49
3.5.19	CHI rate alarm upper/lower limit value (Un\G126 to Un\G141).....	3-50
3.5.20	CHI input signal error detection setting value (Un\G142 to Un\G149)	3-50
3.5.21	HART enable (Un\G160).....	3-51
3.5.22	HART scan list (Un\G161).....	3-51
3.5.23	HART Cycle Time (Un\G162 to Un\G164).....	3-52
3.5.24	HART Maximum Retries (Un\G176 to Un\G183)	3-52
3.5.25	HART device information refresh interval (Un\G191)	3-52
3.5.26	HART Field Device Status (Un\G240, Un\G252, Un\G264...)	3-53
3.5.27	Extended HART Field Device Status (Un\G241, Un\G253, Un\G265...)	3-54
3.5.28	Device Variable Status (Un\G242 & Un\G243, Un\G254 & Un\G255...)	3-55
3.5.29	HART Process Variables (Un\G244 to Un\G251, Un\G256 to Un\G263...)	3-56
3.5.30	HART Command Request (Un\G352 to Un\G483)	3-57
3.5.31	HART Command Answer (Un\G496 to Un\G627)	3-59
3.5.32	Information about HART device (Un\G896 to Un\G966, Un\G968 to Un\G1038...).....	3-60

4 Setup and Procedures before Operation

4.1	Handling Precautions.....	4-1
4.2	Setup and Procedures before Operation	4-2
4.3	Installation of the Module	4-3
4.4	Wiring	4-4
4.4.1	Wiring precautions	4-4
4.4.2	External wiring	4-4
4.5	PLC Parameter Setting.....	4-9
4.5.1	I/O assignment	4-9
4.5.2	Intelligent function module switch settings.....	4-10
4.6	Setting of the HART Devices	4-11

5	Intelligent Function Utility (GX Works2)	
5.1	Addition of a new Module to the Project	5-1
5.2	Switch Setting.....	5-3
5.3	Parameter Setting	5-5
5.4	Auto Refresh Settings.....	5-7
5.5	Writing the Intelligent Function Module Settings to the PLC	5-8
6	Programming	
6.1	Programming Procedure	6-1
6.2	Example 1: ME1AD8HAI-Q combined with PLC CPU.....	6-2
6.2.1	Before creating a program	6-3
6.2.2	Program.....	6-4
6.3	Example 2: ME1AD8HAI-Q used in Remote I/O Network.....	6-9
6.3.1	Before creating a program	6-10
6.3.2	Network Parameter and Program	6-12
7	Troubleshooting	
7.1	Error Code List.....	7-1
7.2	Troubleshooting using the LEDs of the Module.....	7-3
7.2.1	When the "RUN" LED is flashing or turned off	7-3
7.2.2	When the "ERR." LED is on or flashing.....	7-3
7.2.3	When the "ALM" LED is on or flashing	7-3
7.3	When the digital output values cannot be read.....	7-4
7.3.1	When A/D conversion completed flag does not turn ON	7-4
7.4	Checking the Analog Input Module Status.....	7-5
	Index	

1 Overview

This User's Manual describes the specifications, handling and programming methods for the HART analog input module ME1AD8HAI-Q (hereinafter referred to as the ME1AD8HAI-Q) which is used with the CPU modules of the MELSEC System Q. The ME1AD8HAI-Q is exclusively used for current input.

1.1 Features

Multi-channel analog input is available.

By using a single ME1AD8HAI-Q, analog current inputs of 8 points (8 channels) are available. Standard analog input devices with 4 to 20 mA or 0 to 20 mA range can be mixed with HART devices. The analog input range is selectable by the intelligent function module switch setting in GX(IEC) Developer. 2-wire or 4-wire analog transmitters can be connected.

HART master function

The ME1AD8HAI-Q can communicate with up to eight HART-enabled devices. (One HART device connected to each channel.) HART* is a bi-directional industrial field communication protocol used to communicate between intelligent field instruments and host systems.

For this communication no additional wiring is required. Additional device information is communicated using a digital signal that is superimposed on the analog signal. The digital signal contains information from and to the device including device configuration or re-configuration, device status, diagnostics, additional measured or calculated values, etc.

The ME1AD8HAI-Q can operate as a HART master with protocol revision 6.

* HART stands for **H**ighway **A**ddressable **R**emote **T**ransducer. For more information about the HART protocol please refer to section 3.3.6.

FDT/DTM function support

The FDT/DTM can be used for setting and monitoring the HART devices. To use this function, the HART device must have DeviceDTM.

Power supply to 2-wire transmitter

The ME1AD8HAI-Q supplies power to the connected 2-wire transmitters.

Module protection provided by short-circuit protection circuit

If an excessive current flows into the module due to a short circuit of the wiring, the short-circuit protection circuit limits the current, thus protecting the module.

High accuracy

The accuracy is as high as $\pm 0.15\%$ over the specified operating temperature range for the MELSEC System Q.

Changing the input range

The input range (4 to 20 mA or 0 to 20 mA) can easily be set from the GX (IEC) Developer.

A/D conversion system

There are the following five A/D conversion systems.

- Sampling processing

Analog input values are converted into digital values one by one on a channel basis and the digital output value is triggered at every conversion.

- Averaging processing

- Time averaging

A/D conversion is averaged in terms of time on a channel basis and a digital average value is output.

- Count averaging

A/D conversion is averaged in terms of count on a channel basis and a digital average value is output.

- Move averaging

The specified number of digital output values measured per sampling time are averaged.

- Primary delay filter

A digital output value is smoothed according to the preset time constant.

Refer to section 3.3.1 for the details of the A/D conversion system.

Input signal error detection function

A current outside the setting range can be detected.

Warning output

There are the following two warning outputs.

- Process alarm

A warning is triggered if a digital output value falls outside the setting range.

- Rate alarm

A warning is triggered if the varying rate of a digital output value falls outside the preset varying rate range.

Scaling function

A/D conversion values can be converted to percentage values (%) in the preset range and be loaded into the buffer memory. This function can reduce the time required for programming. (Refer to section 3.3.5)

Easy settings using the "Intelligent function utility"

The "Intelligent function utility" is not a required item, however, it is useful for on-screen setting of the intelligent function module parameters (initial setting/auto refresh setting).*

* The "Intelligent function utility" is supported by the ME1AD8HA1-Q if the first 5 digits of the serial number are "14102" or higher.

2 System Configuration

2.1 Applicable Systems

Applicable modules, base units, and No. of modules

- When mounted with a CPU module

The table below shows the CPU modules and base units applicable to the HART Analog Input Module ME1AD8HAI-Q and quantities for each CPU model.

Depending on the combination with other modules or the number of mounted modules, power supply capacity may be insufficient. Pay attention to the power supply capacity before mounting modules, and if the power supply capacity is insufficient, change the combination of the modules.

Applicable CPU module		No. of ME1AD8HAI-Q that can be installed*1	Base unit*2		
CPU type	CPU model		Main base unit	Extension base unit	
Programmable controller CPU	Basic model QCPU	Q00JCPU	Up to 16	●	●
		Q00CPU	Up to 24		
		Q01CPU			
	High performance model QCPU	Q02CPU	Up to 64	●	●
		Q02HCPU			
		Q06HCPU			
		Q12HCPU			
	Process CPU	Q02PHCPU	Up to 64	●	●
		Q06PHCPU			
		Q12PHCPU			
		Q25PHCPU			
	Redundant CPU	Q12PRHCPU	Up to 53	○	●
		Q25PRHCPU			
	Universal model QCPU	Q00UJCPU	Up to 16	●	●
		Q00UCPU	Up to 24		
		Q01UCPU			
		Q02UCPU	Up to 36		
		Q□UD(E)CPU	Up to 64		
		Q50UDEHCPU			
Q100UDEHCPU					
Safety CPU	QS001CPU	—	○	○	
C Controller module	Q06CCPU-V-H01	Up to 64	●	●	
	Q06CCPU-V				
	Q06CCPU-V-B				
	Q12DCCPU-V				

Tab. 2-1: Applicable base units and number of mountable modules

● : Applicable, ○ : N/A

*1 Limited within the range of I/O points for the CPU module.

*2 Can be installed to any I/O slot of a base unit.

NOTE

A ME1AD8HAI-Q can not installed at the main base in a redundant system with QnPRHCPU.

- Mounting to a MELSECNET/H remote I/O station

The table below shows the network modules and base units applicable to the analog input module ME1AD8HAI-Q and quantities for each network module model.

Depending on the combination with other modules or the number of mounted modules, power supply capacity may be insufficient. Pay attention to the power supply capacity before mounting modules, and if the power supply capacity is insufficient, change the combination of the modules.

Applicable network module	No. of ME1AD8HAI-Q that can be installed* ¹	Base unit* ²	
		Main base unit of remote I/O station	Extension base unit of remote I/O station
QJ72LP25-25	Up to 64	●	●
QJ72LP25G			
QJ72LP25GE			
QJ72BR15			

Tab. 2-2: Applicable base units and number of mountable modules in a MELSECNET/H remote I/O station

● : Applicable, ○ : N/A

*1 Limited within the range of I/O points for the network module.

*2 Can be installed to any I/O slot of a base unit.

NOTE

The Basic model QCPU or C Controller module cannot create the MELSECNET/H remote I/O network.

Support of the multiple CPU system

The function version of the HART analog input module supports the multiple CPU system. When using the ME1AD8HAI-Q in a multiple CPU system, refer to the following manual first.

- QCPU User's Manual (Multiple CPU System)

- Intelligent function module parameters

Write intelligent function module parameters to only the control CPU of the ME1AD8HAI-Q.

Compatibility with online module change

The ME1AD8HAI-Q does not support online module change.

Supported software packages

For setting the PLC parameters for a system containing the ME1AD8HAI-Q and programming, the software packages GX Developer, GX IEC Developer and GX Works2 can be used.

In addition, the Intelligent Function Utility of GX Works2 can be used to set the intelligent function module parameters (initial settings/auto refresh settings) of the ME1AD8HAI-Q.

Depending on the CPU module used, a certain version of the software is needed since newly CPU modules are not supported by previous versions.

NOTE

Please check whether the mounted CPU module is supported or not by your version of the programming software.

2.2 How to Check the Function Version and Serial No. of the Modules

Using the programming software GX Developer, GX IEC Developer or GX Works2, the serial No. and the function version can be checked while the PLC is operating.

From the **Diagnostics** menu select **System Monitor** and then select **Product Inf. List**.

Slot	Type	Series	Model name	Points	I/O No.	Master PLC	Serial No	Ver.
PLC	PLC	Q	Q02HCPU	-	-	-	0212200000000000	B
0-0	Intelli.	Q	ME1AD8HAI-Q	32pt	0000	-	1104100000000000	B

Serial number
(first 5 digits)

Function
version

Fig. 2-1: Product Information List for a PLC with a ME1AD8HAI-Q

NOTE

The serial number displayed on the product information screen of GX Developer, GX IEC Developer or GX Works2 describes the function information of the product. The function information of the product is updated when a new function is added.

3 Detailed Description of the Module

3.1 Part Names

This section explains the names of the components for the ME1AD8HAI-Q.

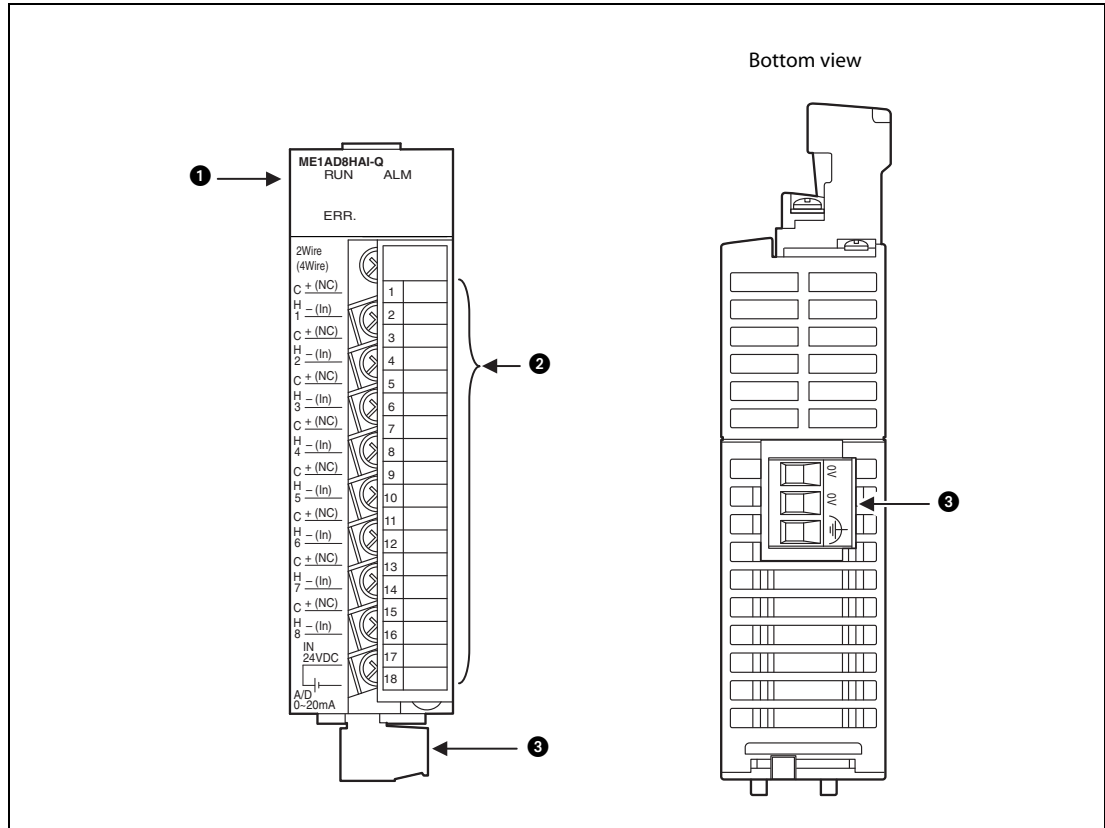

Fig. 3-1: Names of parts

No.	Name	Description
①	RUN	Displays the operating status of the ME1AD8HAI-Q. On: Normal operation Flashing: Intelligent function module setting switch 4 is not set to "0". Off: A watchdog timer error has occurred.
	ERR.	Displays the error status of the ME1AD8HAI-Q. On: Operation error (HART communication error etc.) Flashing: Intelligent function module setting switch 5 is not set to "0". Off: Normal operation
	ALM	Indicates the warning status of the ME1AD8HAI-Q. On: An alarm (process alarm etc.) has occurred. Flashing: An input signal error has occurred. Off: Normal operation
②	Detachable terminal block	Used for connection of the HART input devices (slaves), analog input devices and external power supply.
③	0V/FG connector	Used for FG connection and for connection with the '-' (minus)' terminal of 4 wire devices.

Tab. 3-1: Description of the LEDs and the terminal blocks of the ME1AD8HAI-Q

NOTE

When two or more errors have occurred, the latest error found by the HART analog input module is indicated with the LED.

3.1.1 Signal Layout of the Terminal Block

Terminal No.	Signal name	
1	CH1	+ (NC)
2		- (In)
3	CH2	+ (NC)
4		- (In)
5	CH3	+ (NC)
6		- (In)
7	CH4	+ (NC)
8		- (In)
9	CH5	+ (NC)
10		- (In)
11	CH6	+ (NC)
12		- (In)
13	CH7	+ (NC)
14		- (In)
15	CH8	+ (NC)
16		- (In)
17	External power supply	+ 24VDC
18		0 V

Tab. 3-2: Signal layout for the detachable terminal block of the ME1AD8HAI-Q

For the wiring of the HART analog input module ME1AD8HAI-Q please refer to section 4.4.

3.2 Specifications

The specifications for the ME1AD8HAI-Q are shown in the following table. For general specifications, refer to the operation manual for the CPU module being used.

Item		Specifications								
Number of analog input points		8 points (8 channels)								
Analog input	Current	0 to 20 mA DC 4 to 20 mA DC								
	Absolute maximum input	± 30 mA								
	Input resistance	250 Ω								
	Short-circuit protection	Available								
	Primary filter	5 Hz (3 dB), HART signal is 1200 Hz with 1 mA _{P-P}								
Digital output		16-bit signed binary (-768 to 32767)								
I/O characteristics, maximum resolution		<table border="1"> <thead> <tr> <th>Analog input range</th> <th>Digital output value</th> <th>Maximum resolution</th> </tr> </thead> <tbody> <tr> <td>0 to 20 mA</td> <td rowspan="2">0 to 32000</td> <td>625.0 nA</td> </tr> <tr> <td>4 to 20 mA</td> <td>500.0 nA</td> </tr> </tbody> </table>	Analog input range	Digital output value	Maximum resolution	0 to 20 mA	0 to 32000	625.0 nA	4 to 20 mA	500.0 nA
Analog input range	Digital output value	Maximum resolution								
0 to 20 mA	0 to 32000	625.0 nA								
4 to 20 mA		500.0 nA								
Accuracy *1 (relative to digital output range)		±0.15% (±48 digit *2)								
Cycle time		80 ms (Independent to the number of used channels)								
Insulation method	Between the I/O terminals and PLC power supply	Photo-coupler insulation								
	Between analog input channels	Non-insulated								
HART modem		FSK Physical Layer, multiplexed								
HART functions		- Protocol Revision 6 support - 4 Process variables support (PV, SV, TV, QV) - FDT/DTM support								
Number of I/O occupied points		32 points (I/O assignment: Intelligent 32 points)								
External wiring connection system		18-points terminal block								
Applicable wire size		Refer to the HART specification for more details. The external power supply voltage of the ME1AD8HAI-Q should be enough for correct operation of the analog transmitter. *3 *4								
Applicable solderless terminals		R1.25-3 (Solderless terminals with sleeves cannot be used.)								
External supply power	Voltage	24 V DC (+20%, -15%); ripple, spike within 500mV _{P-P}								
	Current	0.3 A								
	Inrush current	5.5 A within 200 μs								
Online module change		Not supported								
Internal current consumption (5 VDC)		0.32 A								
Weight		0.19 kg								

Tab. 3-3: Specifications of ME1AD8HAI-Q

- *1 ME1AD8HAI-Q needs to be powered on 30 minutes prior to operation for compliance to the specification (accuracy).
- *2 "digit" indicates a digital value.
- *3 Use case:
For distances up to 800 m, the wire size of 0.51 mm diameter with 115 nF/km cable capacitance and 36.7 Ω/km cable resistance can be applied.
- *4 Refer to the calculation example shown in section 4.4.2 (External wiring).

3.2.1 I/O conversion characteristic

The I/O conversion characteristic represents the angle formed by a straight line when the analog current signals from outside the programmable controller are converted to digital values.

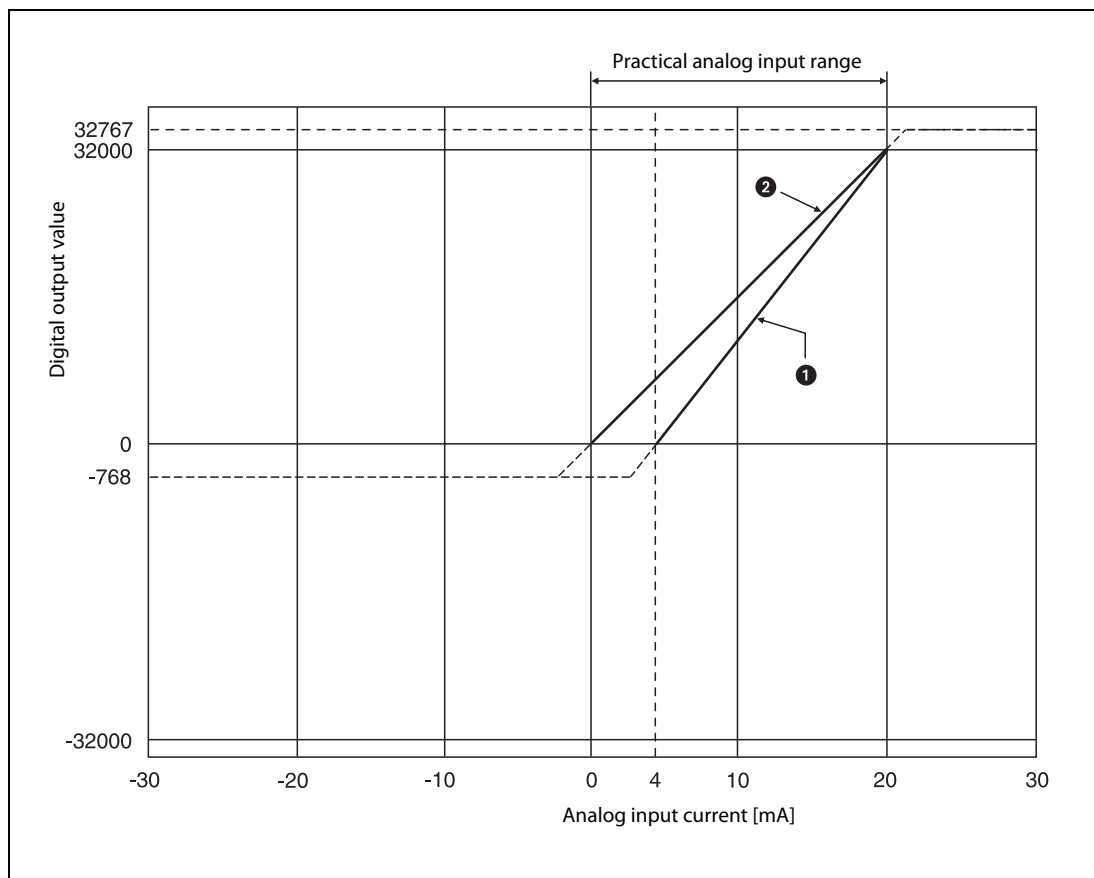

Fig. 3-2: Current input characteristics of the ME1AD8HAI-Q

- ① Analog input range setting: 4 to 20 mA
- ② Analog input range setting: 0 to 20 mA

NOTES

Choose the appropriate analog input range for each channel according to the specifications of the connected analog input device.

If these ranges are exceeded, the maximum resolution and accuracy may not fall within the performance specifications. (Avoid use shown by the dotted lines in the above table.)

Do not input an analog input current of ± 30 mA or more. The input elements may be damaged.

When an analog value that exceeds the range of the digital output value is entered, the digital output value will be fixed at the maximum or minimum value (32767 resp. -768).

3.2.2 Accuracy

The reference accuracy is the accuracy relative to the digital output range.

An accuracy of $\pm 0.15\%$ is maintained over the whole operating temperature range of the MELSEC System Q (0 to $+55$ °C).

3.2.3 External Dimensions

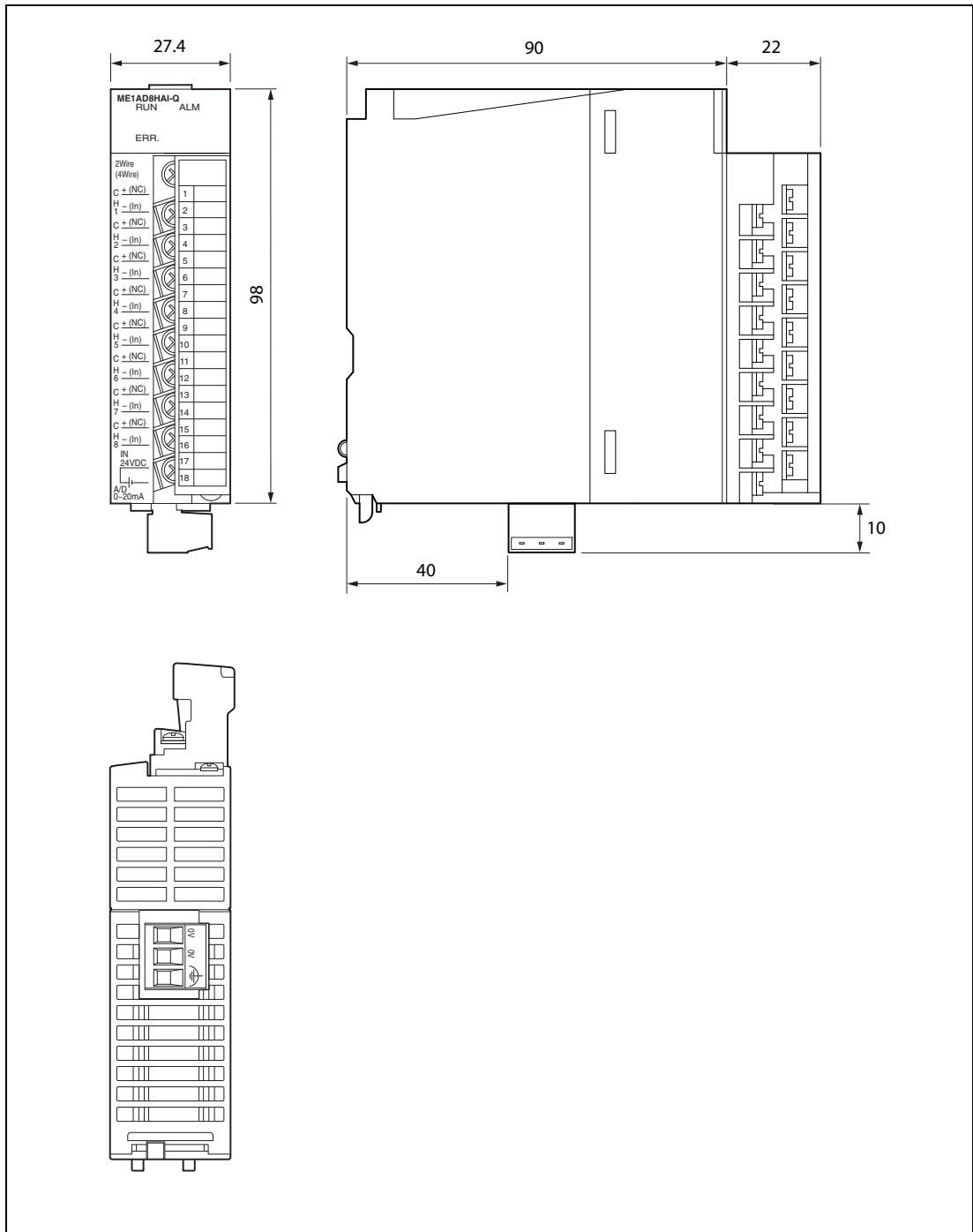

Fig. 3-3: Dimensions of the ME1AD8HAI-Q

(Unit: mm)

3.3 Functions of the HART Analog Input Module

Item	Function	Reference section
A/D conversion enable/disable setting	Specifies whether to enable or disable the A/D conversion for each channel.	Section 3.5.2
A/D conversion method	<ul style="list-style-type: none"> • Sampling processing The A/D conversion for analog input values is performed successively for each channel, and the digital output value is output upon each conversion. • Averaging processing <ul style="list-style-type: none"> – Time averaging A/D conversion is averaged in terms of time on a channel basis and a digital average value is output. – Count averaging A/D conversion is averaged in terms of count on a channel basis and a digital average value is output. – Move averaging The specified number of digital output values measured per cycle time are averaged. • Primary delay filter A digital output value is smoothed according to the preset time constant. 	Section 3.3.1
Maximum and minimum values hold function	The maximum and minimum values of the digital output values are retained in the module.	Section 3.3.2
Input signal error detection function	A current outside the setting range can be detected.	Section 3.3.3
Warning output function	<ul style="list-style-type: none"> • Process alarm A warning is output if a digital output value falls outside the setting range. • Rate alarm A warning is output if the varying rate of a digital output value falls outside the preset varying rate range. 	Section 3.3.4
Scaling function	Conversion of A/D conversion values to preset percentage values and loading into the buffer memory is available. Programming steps for the scaling can be eliminated.	Section 3.3.5
HART Master function	<ul style="list-style-type: none"> • HART communication support The ME1AD8HAI-Q can communicate with up to eight HART-enabled devices. (One HART device connected to each channel.) Communication occurs using standard instrumentation grade wire and using standard wiring and termination practices – no additional wiring is required. • FDT/DTM function support Using a commercially available FDT, reading/writing the HART transmitter's parameters and monitoring the HART transmitter status are executable via the ME1AD8HAI-Q. 	Section 3.3.6

Tab. 3-4: Functions of the ME1AD8HAI-Q

3.3.1 A/D conversion methods

Sampling processing

A/D conversion is performed successively for analog input values, and the converted digital output values are stored in the buffer memory.

Averaging processing

- Time averaging

A/D conversion is made for the preset period of time, the sum of values other than the maximum and minimum values is averaged, and the result is stored into the buffer memory.

The number of processing within the set time depends on the cycle time (Fixed to 80 ms independently to the number of channels enabled for A/D conversion) and can be calculated using the following formula:

$$\text{Number of processings [times]} = \text{Set time [ms]} / 80 \text{ [ms]}$$

Example:

Number of processings when setting 500 ms for the set time: $500/80 = 6.25$ [times] → 6 [times]

- Count averaging

A/D conversion is made the preset number of times, the sum of values other than the maximum and minimum values is averaged, and the result is stored into the buffer memory.

The time required for the count-based average value to be stored into the buffer memory varies depends on the cycle time (Fixed to 80 ms independently to the number of channels enabled for A/D conversion) and can be calculated using the following formula:

$$\text{Processing time [ms]} = \text{Set count} \times 80 \text{ [ms]}$$

Example:

Processing time when setting 5 (times) for the average processing count: $5 \times 80 = 400$ [ms]

- Moving average

The specified count of digital output values imported per sampling period are averaged to find a value, which is then stored into the buffer memory. Since average processing is performed with data shifted per sampling, the most recent digital output value is obtainable.

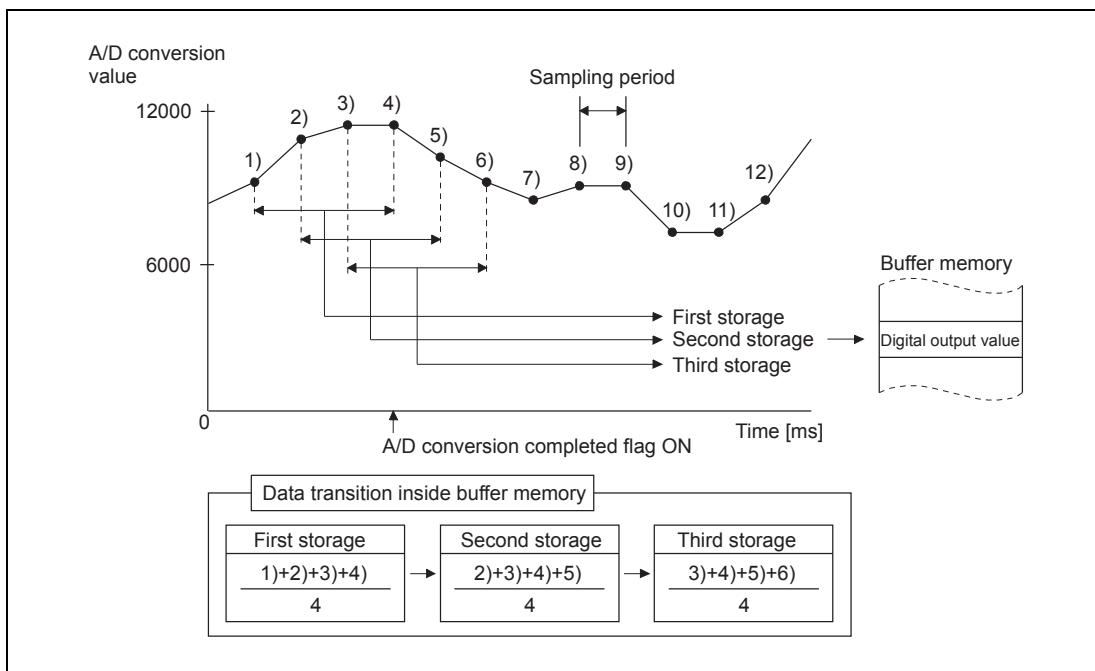

Fig. 3-4: Moving average processing at the preset count of 4 times

Primary delay filter

A digital value whose transient noise has been smoothed is output according to the preset time constant. The degree of smoothing varies with the time constant setting.

The relational expression of the time constant and digital output value is indicated below.

[If n = 1]
 $Y_n = 0$

[If n = 2]*

$$Y_n = y_{n-1} + \frac{\Delta t}{\Delta t + T_A} (y_n - y_{n-1})$$

[If n ≥ 3]

$$Y_n = Y_{n-1} + \frac{\Delta t}{\Delta t + T_A} (y_n - Y_{n-1})$$

Y_n: Current digital output value
 Y_{n-1}: Immediately preceding digital output value
 n: Sampling count
 T_A: Time constant [s]

y_n: Pre-smoothing digital output value
 y_{n-1}: Immediately preceding presmoothing digital output value
 Δt: Cycle time (0.08)[s]

*The A/D conversion completed flag turns ON when n ≥ 2.

Example 1:

Digital output value when the analog input value varies from 4 to 10 mA

The variation of the digital output value at the time constant setting of 1000 ms (1 s) is as shown below. 1000 ms (1 s) after the analog input value has reached 10 mA, the digital output value reaches 63.2 % of the value attained when the sampling processing is selected.

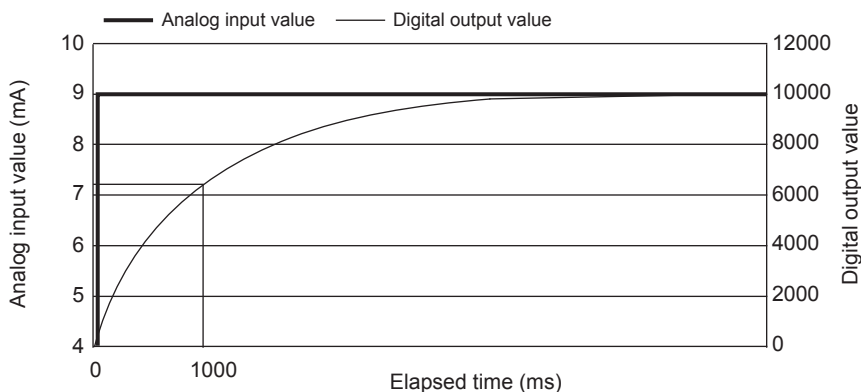

Example 2:

Digital output value when the variation of the analog input value has a ringing waveform

The variations of the digital output values at the time constant setting of 2000 ms (2 s), at the time constant setting of 1000 ms (1 s), and at the moving average processing of 16 times are as shown below.

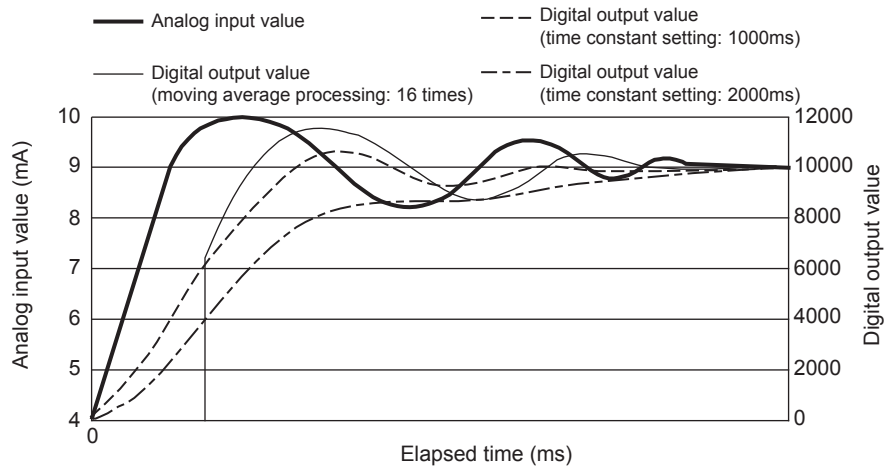

3.3.2 Maximum and minimum values hold function

The maximum and minimum values are held in the buffer memory channel by channel.

The maximum and minimum values are cleared to 0 when the maximum value/minimum value reset request (YD) or operating condition setting request (Y9) is turned ON, and new maximum and minimum values are stored when conversion is started.

Since the area for storing the maximum and minimum values can be rewritten with the sequence program, the maximum and minimum values within a specific period of time can be checked.

When the scaling function is enabled, values after scaling conversion are stored as the maximum and minimum values. For the scaling function, refer to section 3.3.5

3.3.3 Input signal error detection function

If the input current rose to or above the input signal error detection upper limit value or fell to or below the lower limit value, the input signal error detection flag (Un\G49) and input signal error detection signal (XC) turn ON and the ALM LED flickers to indicate the error.

When the input signal error detection flag (Un\G49) turns ON for a channel, a digital output value immediately before the error detection is held for the channel, and the A/D conversion completed flag (Un\G10) of the corresponding channel turns OFF.

By bringing the analog input value within the setting range and then turning ON the error clear request (YF), the input signal error detection flag (Un\G49) and input signal error detection signal (XC) turn OFF.

When the analog input value returns to within the setting range, A/D conversion is resumed independently of whether the input signal error detection flag (Un\G49) and input signal error detection signal (XC) are reset or not, the A/D conversion completed flag (Un\G10) of the corresponding channel turns ON again after the first updating. (The ERR. LED remains flickering.)

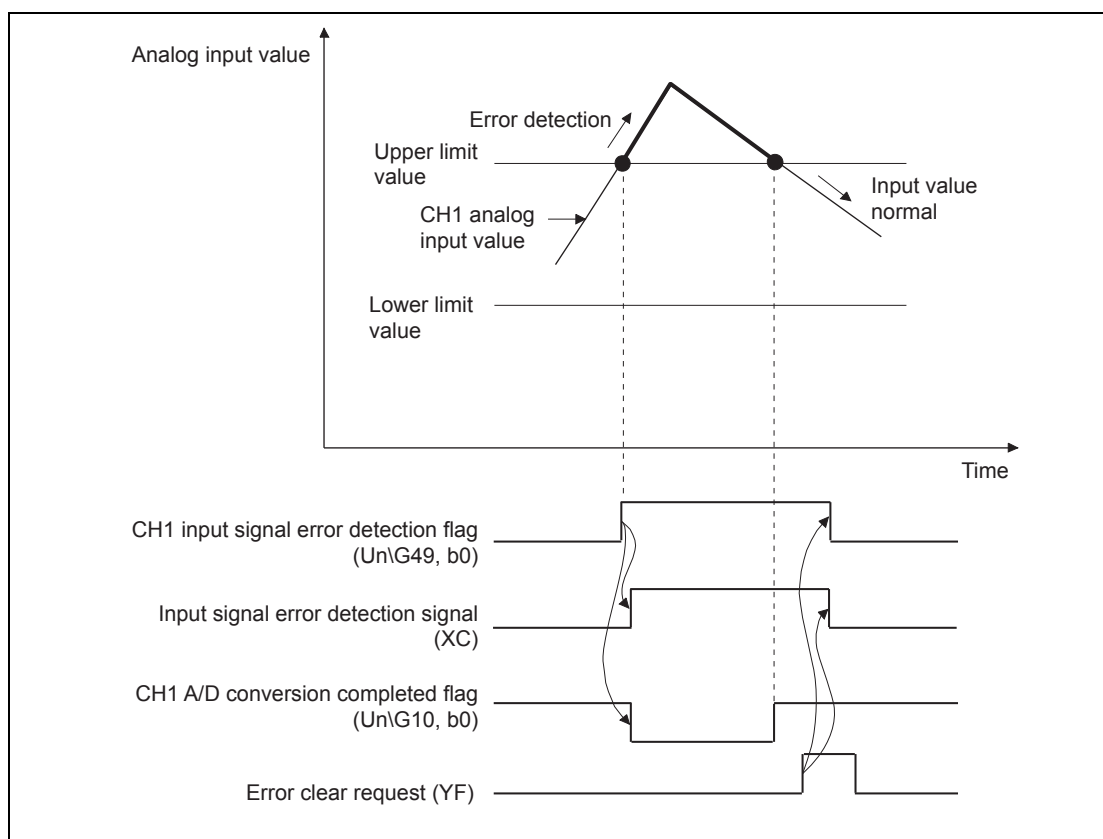

Fig. 3-5: Input signal error detection function

This function is executed at every sampling processing. Perform the following procedure to use this function.

- Set the input signal error detection setting value for the corresponding channel.
- Enable the A/D conversion of the corresponding channel.
- Enable the input signal error detection of the corresponding channel.
- Turn ON the operating condition setting request (Y9).

3.3.4 Warning output function

Process alarm

If the detected digital output value rose to or above the process alarm upper upper limit value or fell to or below the process alarm lower lower limit value and entered the warning output range zone, the warning output flag (process alarm)(Un\G50) and warning output signal (X8) turn ON and the ALM LED is lit to indicate the warning.

A warning will be output according to the following digital output values.

Item	Digital value causing warning output	
Value set in scaling enable/disable setting (Un\G53)	0: Disable	CH□ digital output value (Un\G11 to Un\G18)
	1: Enable	CH□ scaling value (Un\G54 to Un\G61)

Tab. 3-5: The source for the warning depends on the setting in the buffer memory address Un\G53

The warning output signal (X8) turns OFF only when all channels return to within the setting range.

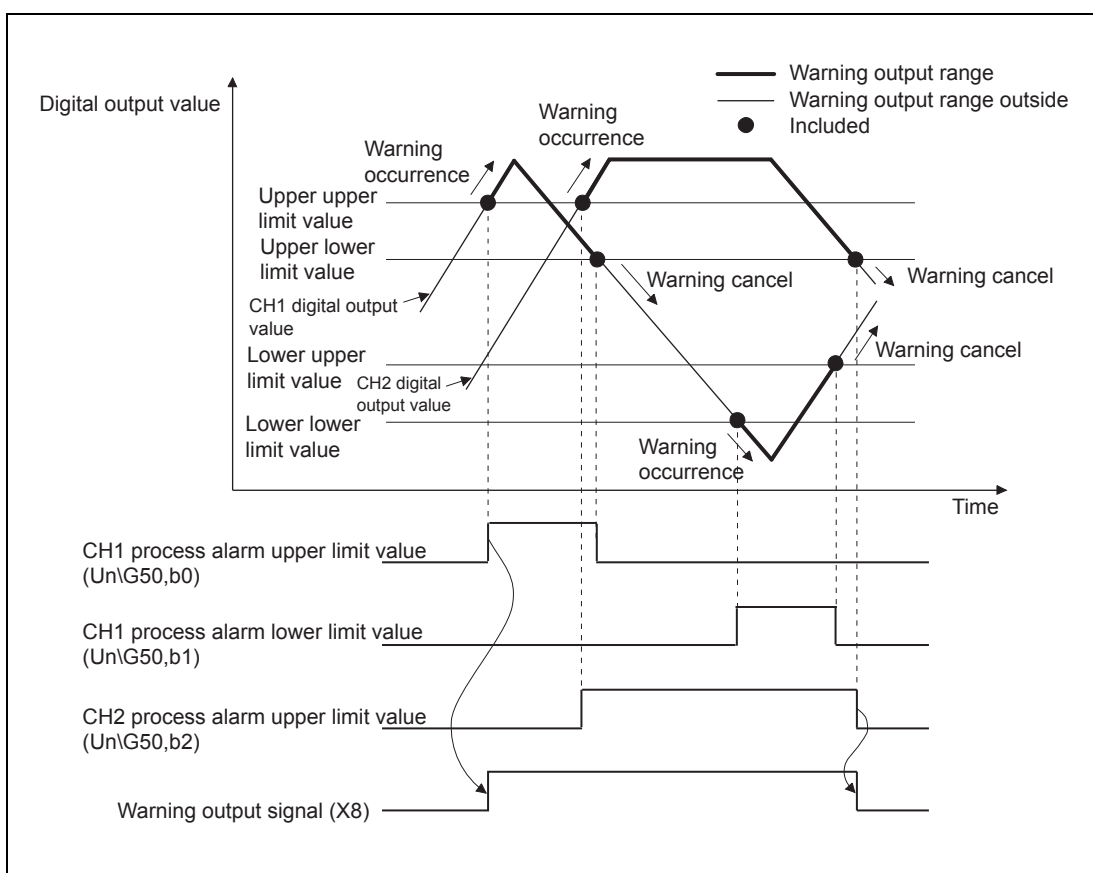

Fig. 3-6: Warning output function (process alarm)

When time or count averaging is specified, this function is executed at intervals of the preset averaging time or averaging count. When any other A/D conversion system (sampling processing, moving average, primary delay filter) is specified, this function is executed at intervals of the cycle time.

To use the scaling function, be sure to consider the scaling conversion before setting the CH□ process alarm upper/lower limit value.

Rate alarm

If the range of change in the digital output value sampled at intervals of the rate alarm warning detection period is equal to or greater than the rate alarm upper limit value or is equal to or less than the rate alarm lower limit value, the warning output flag (rate alarm) (Un\G51) and warning output signal (X8) turn ON and the ALM LED is lit to indicate the warning of the rate alarm.

If, after the output of the warning, the rate fell below the rate alarm upper limit value or rose above the rate alarm lower limit value and returned to within the setting range, "0" is stored into the bit position corresponding to the channel number of the warning output flag (rate alarm) (Un\G51). The warning output signal (X8) turns OFF only when all channels return to within the setting range

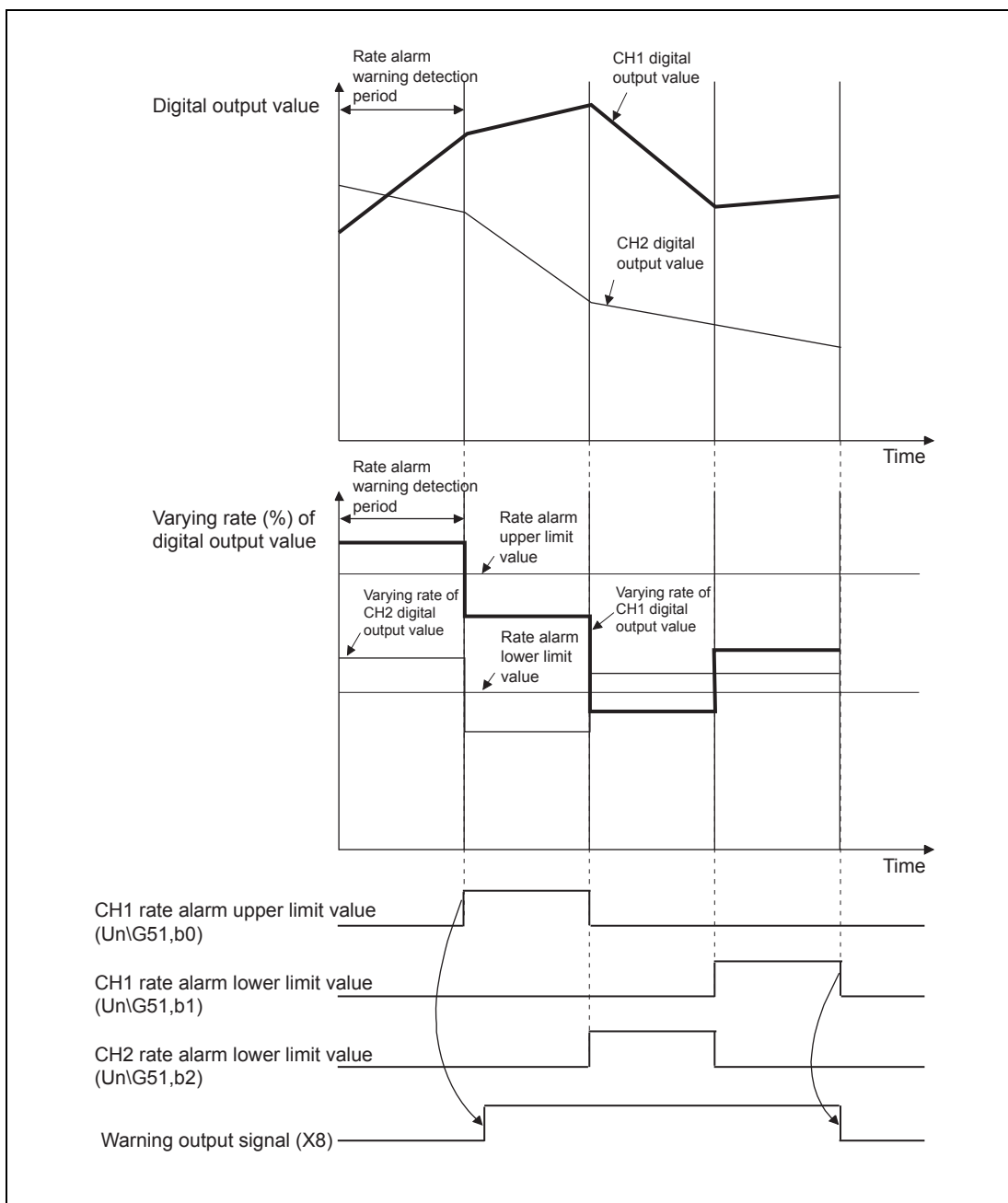

Fig. 3-7: Warning output function (rate alarm)

Set the rate alarm upper limit value/lower limit value in 0.1 %/s increments relative to the maximum value (32000) of the digital output value. The setting range is -32768 to 32767 (-3276.8 % to 3276.7 %).

The setting range of the rate alarm warning detection period is 80 to 5000 ms. When the period is set to 5000 ms, the digital values are compared at intervals of 5 seconds to detect the varying rate.

The rate alarm is judged by converting the rate alarm upper/lower limit value into the digit value per rate alarm warning detection period. The expression for the value used to make judgment per rate alarm warning detection period is as follows:

$$\text{Value used to make judgment per rate alarm warning detection period [digit]} = \text{rate alarm upper limit value or lower limit value} \times 0.001 \times \text{maximum value of the digital output value} \times \text{rate alarm warning detection period} \div 1000$$

● Example

The following is set for channel 1:

- Upper limit value of change rate: 30 % per second (300 is stored in buffer memory)
- Maximum digital output value: 32000
- Rate alarm warning detection period: 80 ms

The value [digit] used at every rate alarm warning detection period can be calculated as follows:

$$300 \times 0.001 \times 32000 \times 80 / 1000 = 768 \text{ (digit)}$$

Therefore, the current value is compared with the previous value every 80 ms in channel 1, and whether a difference of 768 (digit) or more is identified between them or not is determined.

The rate alarm is useful to watch the varying rate of the digital output value in a limited range.

- Example of setting the rate alarm upper limit value/lower limit value when it is desired to watch that the digital output value increases within the specified range

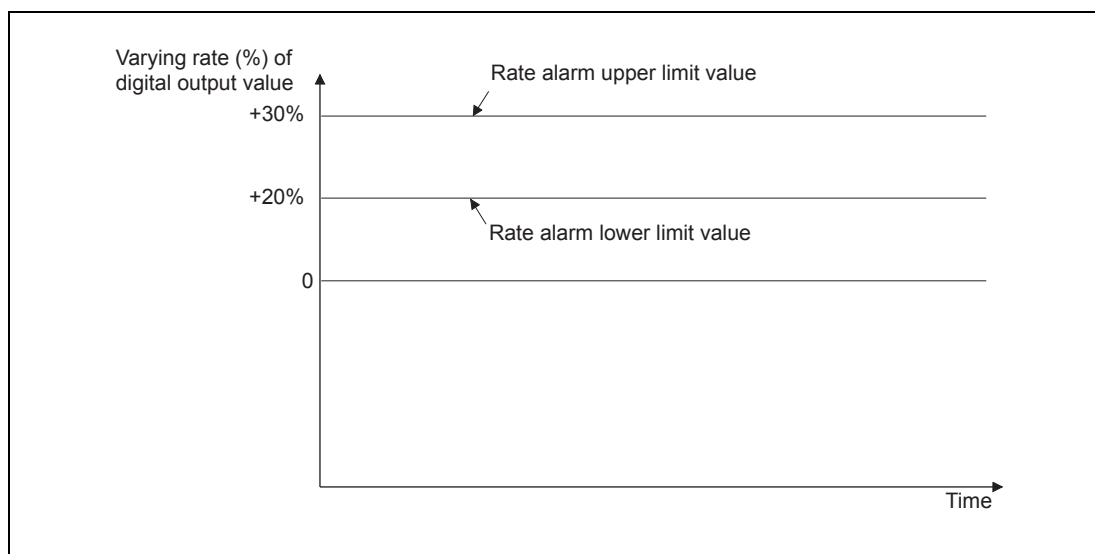

Fig. 3-8: Rate alarm for increasing values

- Example of setting the rate alarm upper limit value/lower limit value when it is desired to watch that the digital output value decreases within the specified range

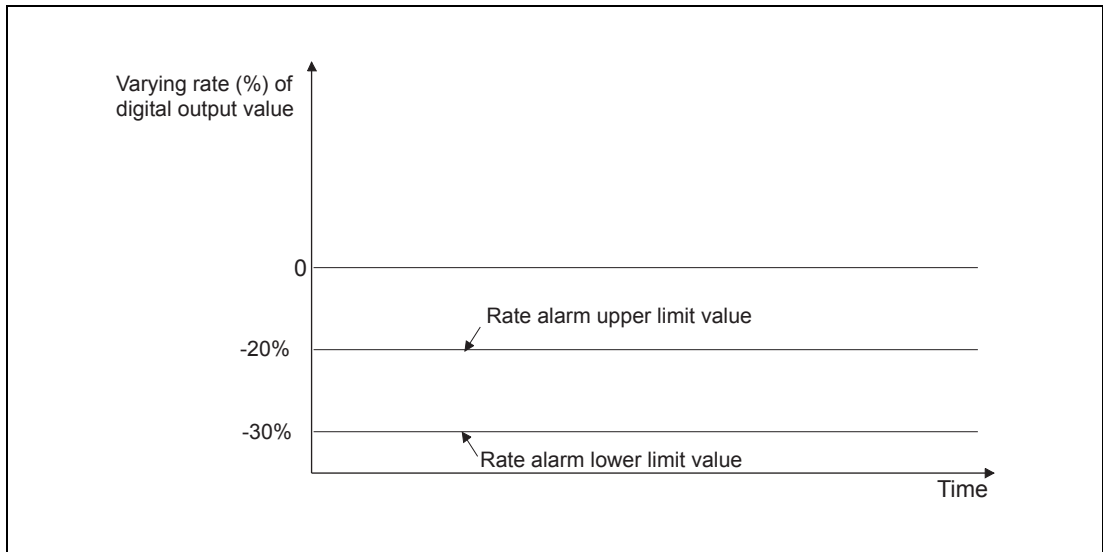

Fig. 3-9: Rate alarm for decreasing values

- Example of setting the rate alarm upper limit value/lower limit value when it is desired to watch that the digital output value increases/decreases within the specified range

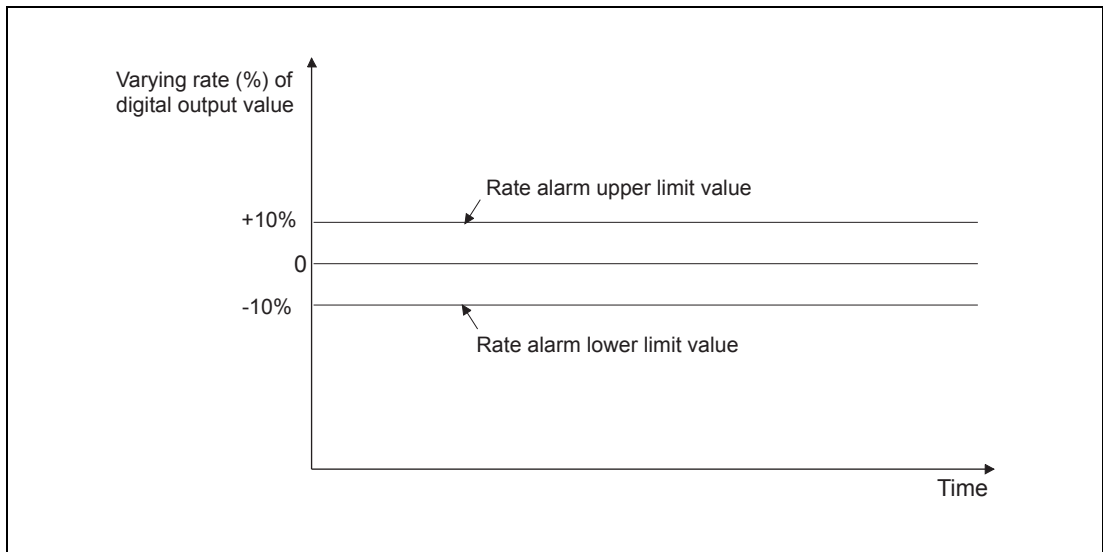

Fig. 3-10: Rate alarm for increasing and decreasing values

3.3.5 Scaling Function

With this function, A/D conversion values are converted to rate values and loaded into the buffer memory.

A digital value stored in CH□ digital output value (Un\G11 to Un\G18) is converted to a value in the range set by CH□ scaling upper/lower limit value (Un\G62 to Un\G77). The converted value is stored in CH□ scaling value storage area (Un\G54 to Un\G61).

The scaling function is used for processed values when using the averaging processing or primary delay filter.

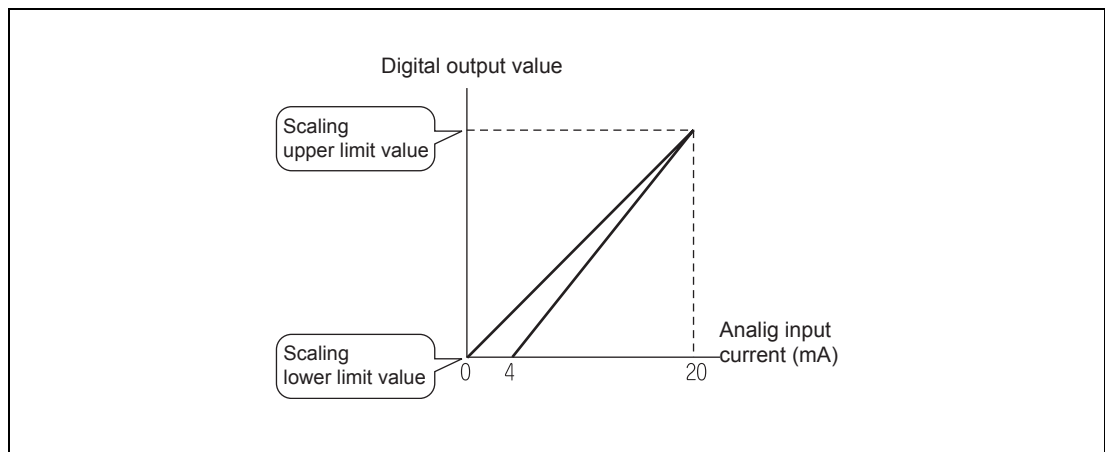

Fig. 3-11: Scaling function for input range settings 0 to 20 mA and 4 to 20 mA

How to calculate a scaling value is explained below.

$$\text{Scaling value} = \frac{Dx \times (SH - SL)}{D_{max}} + SL$$

Dx: Digital output value

DMax: The maximum digital output value in the input range being used (32000)

SH: Scaling upper limit value

SL: Scaling lower limit value

● Example

Using the input range from 4 to 20 mA, 14 mA input result in a digital output value (Dx) of 20000. With a scaling upper limit value (SH) of 2000 and a scaling lower limit value (SL) of 500 the scaling value for 14 mA input is:

$$\begin{aligned} \text{Scaling value} &= \frac{20000 \times (2000 - 500)}{32000} + 500 \\ &= 1437.5\dots \\ &= 1437 \end{aligned}$$

Fig. 3-12: Example for the calculation of the scaling value

NOTE | In the calculation of the scaling value, the digits following the decimal point are omitted.

3.3.6 HART Master Function

What is HART?

HART stands for **H**ighway **A**ddressable **R**emote **T**ransducer.

HART Communication is a bi-directional industrial field communication protocol used to communicate between intelligent field instruments and host systems. A host system can be a handheld device, a Distributed Control System, Asset Management System, Safety System or a PLC.

There are several reasons to have a host communicate with a field instrument. These include:

- Device Configuration or re-configuration
- Device Diagnostics
- Device Troubleshooting
- Reading the values of additional measurements provided by the device
- Device Health and Status
- And much more!

How HART Works

When using the ME1AD8HAI-Q, HART communication takes place between the analog input module and an HART-enabled field device, for example a temperature transmitter. The ME1AD8HAI-Q can communicate with up to eight HART-enabled devices. (One HART device connected to each channel.)

Communication occurs using standard instrumentation grade wire and using standard wiring and termination practices – no additional wiring is required.

HART provides two simultaneous communication channels: the 4 to 20 mA analog signal and a digital signal. The 4 to 20 mA signal communicates the primary measured value fast robust and reliable. Additional device information is communicated using a digital signal that is superimposed on the analog signal. The digital signal contains information from the device including device status, diagnostics, additional measured or calculated values, etc.

The HART protocol makes use of the Bell 202 Frequency Shift Keying (FSK) standard to superimpose digital communication signals at a low level on top of the 4 to 20 mA analog signal.

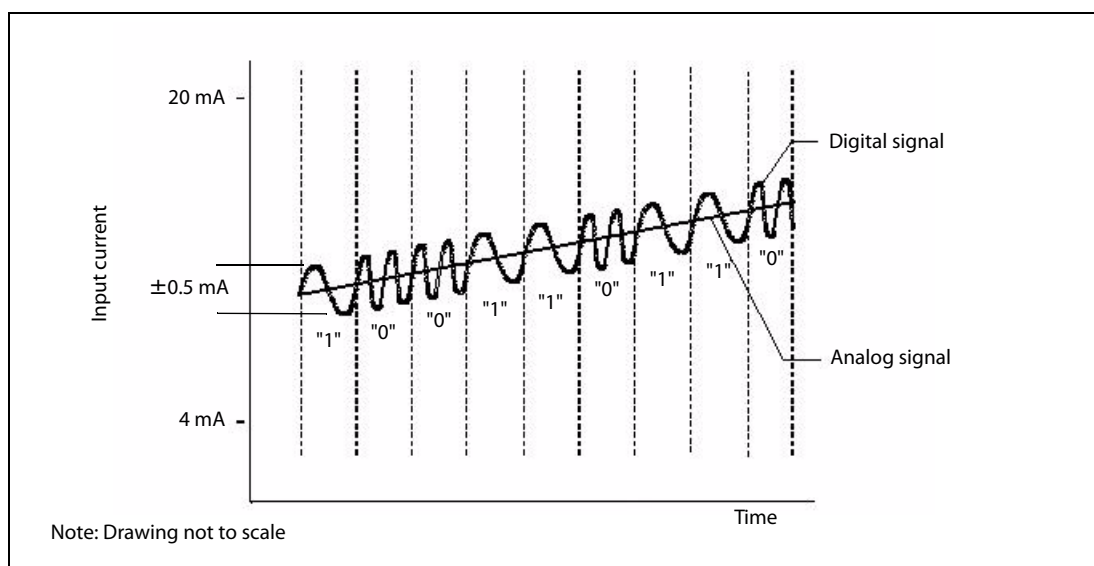

Fig. 3-13: Digital communication is superimposed on the analog signal

A digital signal with a frequency of 2200 Hz is interpreted as logical "0", whereas a frequency of 1200 Hz is interpreted as logical "1".

The HART protocol communicates without interrupting the 4 to 20 mA signal and allows a host appli-

cation (in this case the ME1AD8HAI-Q) to get two or more digital updates per second from a field device. As the digital FSK signal is phase continuous, there is no interference with the analog 4 to 20 mA signal.

HART is a master/slave protocol which means that a field (slave) device only speaks when spoken to by the ME1AD8HAI-Q (master). This is done by commands send by the ME1AD8HAI-Q. Codes vary by manufacturer/device.

Examples for commands:

- Set Primary Variable Units
- Set Upper Range
- Set Lower Range
- Set Damping Value
- Set Tag
- Set Date
- Set Descriptor
- Perform Loop Test - Force loop current to specific value
- Initiate Self Test - Start device self test
- Get More Status Available Information

NOTE

The supported commands are depended on the specification of the HART transmitter.

The ME1AD8HAI-Q can operate as a HART master with protocol revision 6.

HART Data

The following list is only a brief overview of the data transmitted via the HART protocol. Fore more information please refer to the description of the buffer memory (Section 3.5.1).

- Digital data: 35 to 40 valuable data items standard in every HART device
- Device identification: device tag, supplier, device type and revision, device serial number
- Calibration data: upper and lower range values, upper and lower sensor limits, PV damping, last calibration date
- Process variables: primary variable plus secondary measurements and multivariable parameters
- Status/diagnostic alerts: device malfunction, configuration change, power fail restart, loop current fixed or saturated, primary or secondary variable out of limits, communication error etc.

More information

This short overview about the HART protocol is only a extract of the information provided on the website of the HART Communication Foundation. You can find much more information about HART and answers to frequently asked questions on their website at www.hartcomm2.org.

FDT/DTM function support

Support of FDT/DTM function.

Using a commercially available FDT, reading/writing the HART transmitter's parameters and monitoring the HART transmitter status are executable via the ME1AD8HAI-Q.

Refer to section 4.6 (Setting of the HART Devices) for more details about the FDT/DTM system structure.

3.4 I/O Signals for the Programmable Controller CPU

3.4.1 List of I/O signals

Note that I/O numbers (X/Y) shown in this chapter and thereafter are the values when the start I/O number for the ME1AD8HAI-Q is set to 0 (i.e. the module is mounted to the I/O slot 0 of the main base unit).

Signal direction CPU Module ← ME1AD8HAI-Q		Signal direction CPU Module → ME1AD8HAI-Q	
Device No. (Input)	Signal name	Device No. (Output)	Signal name
X0	Module ready	Y0	Use prohibited
X1	Use prohibited	Y1	
X2		Y2	
X3	HART device variables access flag	Y3	HART device variables access request
X4	Use prohibited	Y4	Use prohibited
X5		Y5	
X6		Y6	
X7		Y7	
X8	Warning output signal	Y8	
X9	Operating condition setting completed flag	Y9	Operating condition setting request
XA	Use prohibited	YA	Use prohibited
XB		YB	
XC	Input signal error detection signal	YC	
XD	Maximum value/minimum value reset completed flag	YD	Maximum value/minimum value reset request
XE	A/D conversion completed flag	YE	Use prohibited
XF	Error flag	YF	Error clear request
X10 to X1F	Use prohibited	Y10 to Y1F	Use prohibited

Tab. 3-6: I/O signals of the ME1AD8HAI-Q

NOTE

The "Use prohibited" signals cannot be used by the user since they are for system use only. If these are turned ON/OFF by the sequence program, the performance of the HART analog input module cannot be guaranteed.

3.4.2 Details of I/O signals

Input signals

Device No.	Signal Name	Description
X0	Module ready	<ul style="list-style-type: none"> When the programmable controller CPU is powered on or reset, this signal turns on once the preparation for A/D conversion has been completed. Afterwards A/D conversion processing is performed. When the analog input module has a watchdog timer error*1, "Module ready" (X0) turns OFF (In this case A/D conversion processing is not performed.)
X3	HART device variables access flag	<ul style="list-style-type: none"> This signal turns ON while the HART device variables and device variable status (Buffer Memory Un\G240 to Un\G335) are accessed for update. If data consistency for the HART device variables and device variables status is required, do not read the variables while this signal is ON and set the Y3 signal when reading the variables.
X8	Warning output signal	<p>The Warning output signal (X8) turns ON at detection of a process alarm or rate alarm.</p> <ul style="list-style-type: none"> Process alarm <ul style="list-style-type: none"> This signal turns ON when the digital output value falls outside the setting range set to the process alarm upper/lower limit values (Un\G86 to Un\G117) on any of the channels enabled for A/D conversion after the process alarm function has been made valid. As soon as the digital output values return to within the setting ranges on all channels enabled for A/D conversion, this signal turns OFF automatically and the ALM LED is also extinguished. Rate alarm <ul style="list-style-type: none"> This signal turns ON when the varying rate of the digital output value falls outside the varying rate range set to the rate alarm upper/lower limit values (Un\G126 to Un\G141) on any of the channels enabled for A/D conversion after the rate alarm function has been made valid. As soon as the varying rates of the digital output values return to within the preset varying ranges on all channels enabled for A/D conversion, this signal turns OFF automatically and the ALM LED is also extinguished. <div style="text-align: right; margin-right: 50px;"> <p>-----> Performed by the HART Analog Input module —————> Performed by the sequence program</p> </div> <p>Warning output flag (Un\G50, Un\G51)</p> <p>Warning output signal (X8)</p>

Tab. 3-7: Detailed description of the input signals (Signal direction ME1AD8HAI-Q → CPU Module)

*1 A watchdog timer error occurs when the program calculations are not completed within the scheduled time due to malfunctions of the analog input module hardware.
 When a watchdog timer error occurs, the RUN LED of the analog input module turns off.

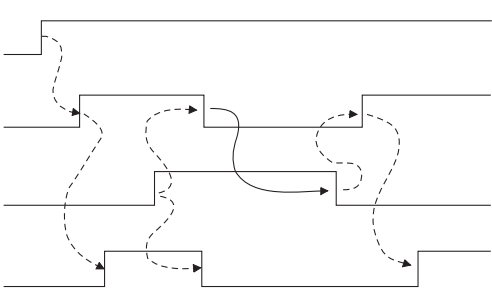
Device No.	Signal Name	Description
X9	Operating condition setting completed flag	<ul style="list-style-type: none"> This signal is used as an interlock condition to turn ON/OFF the Operating condition setting request (Y9) when any of the following settings has been changed. <ul style="list-style-type: none"> A/D conversion enable/disable setting (Un\G0) CH□ Average time/Average number of times/Moving average/Time constant settings (Un\G1 to Un\G8) Averaging process specification (Un\G24, Un\G25) Input signal error detection extended/input signal error detection setting (Un\G47) Warning output settings (Un\G48) Scaling enable/disable setting(Un\G53) CH□ scaling upper/lower limit value (Un\G62 to Un\G77) CH□ process alarm upper/lower limit value (Un\G86 to Un\G117) CH□ rate alarm warning detection period (Un\G118 to Un\G125) CH□ rate alarm upper/lower limit value (Un\G126 to Un\G141) CH□ input signal error detection setting value (Un\G142 to Un\G149) When the operating condition setting completed flag (X9) is OFF, A/D conversion processing is not performed. The operating condition setting completed flag (X9) turns OFF when operating condition setting request (Y9) is ON. <div style="text-align: right; margin-bottom: 10px;"> <p>-----> Performed by the HART Analog Input Module</p> <p>—————> Performed by the sequence program</p> </div>  <p>Digital output values are cleared immediately after the Operating condition change request (Y9) turns ON. Therefore, check the status of the A/D conversion completed flag before reading digital outputs.</p> <p>NOTE If the "Intelligent function utility" is used for configuration, the settings made with this function are restored under the following conditions:</p> <ul style="list-style-type: none"> CPU Power off → CPU RUN CPU RESET → CPU RUN CPU STOP → CPU RUN

Tab. 3-8: Detailed description of the input signals (Signal direction ME1AD8HAI-Q → CPU Module)

Device No.	Signal Name	Description
XC	Input signal error detection signal	<ul style="list-style-type: none"> This signal turns ON when the analog input value falls outside the setting range set to the Input signal error detection setting value (Un\G142 to Un\G149) on any of the channels enabled for A/D conversion after the Input signal error detection is made valid. When the Input signal error detection signal turns ON <ul style="list-style-type: none"> The A/D conversion completed flag (Un\G10) of the corresponding channel turns OFF. The digital output value is held as at the time of error detection. The ALM LED flickers. By bringing the analog input value within the setting range and then turning ON the Error clear request (YF), the Input signal error detection signal (XC) turns OFF and the ALM LED is extinguished. When the analog input value returns to within the setting range, A/D conversion is resumed independently of whether the Input signal error detection signal (XC) is reset or not, and after the first updating, the A/D conversion completed flag (Un\G10) of the corresponding channel turns ON again. The processing, such as averaging processing or primary delay filter, starts from the first time after resumption of A/D conversion.
XD	Maximum value/minimum value reset completed flag	<ul style="list-style-type: none"> This signal turns ON when the maximum value/minimum value stored at any of the buffer memory addresses 30 to 45 (Un\G30 to Un\G45) is reset by turning ON the Maximum value/minimum value reset request (YD).
XE	A/D conversion completed flag	<ul style="list-style-type: none"> This signal turns ON when conversion for all of the channels that are conversion enabled has been completed. When the external supply power to the ME1AD8HAI-Q switches OFF, the A/D conversion completed flag turns OFF, and A/D conversions stop with the previous digital output values being held. <p>When the external supply power switches ON, A/D conversions resume, and as soon as all conversion-enabled channels have completed conversions, the A/D conversion completed flag turns ON.</p> <p>The processing, such as averaging processing or primary delay filter, starts from the first time after resumption of A/D conversion.</p>

Tab. 3-8: Detailed description of the input signals (Signal direction ME1AD8HAI-Q → CPU Module)

Device No.	Signal Name	Description
XF	Error flag	<ul style="list-style-type: none"> The error flag turns ON when a write error occurs. To clear the error code, set the error clear request (YF) to ON. <p>-----> Performed by the A/D converter module —————> Performed by the sequence program</p> <p>Error code(Un\G19)</p> <p>Error flag (XF)</p> <p>Error clear request (YF)</p>

Tab. 3-8: Detailed description of the input signals (Signal direction ME1AD8HAI-Q → CPU Module)

Output signals

Device No.	Signal Name	Description
Y3	HART device variables access request	If data consistency for the HART device variables and device variables status (Buffer Memory Un\G240 to Un\G335) is required, turn this signal ON while accessing the variables and do not read the variables while the X3 signal is ON.
Y9	Operating condition setting request	<ul style="list-style-type: none"> Turning this signal ON makes any of the following settings valid. <ul style="list-style-type: none"> A/D conversion enable/disable setting (Un\G0) CH Average time/Average number of times/Moving average/Time constant settings (Un\G1 to Un\G8) Averaging process specification (Un\G24, Un\G25) Input signal error detection setting (Un\G47) Warning output settings (Un\G48) Scaling enable/disable setting(Un\G53) CH□ scaling upper/lower limit value(Un\G62 to Un\G72) CH□ process alarm upper/lower limit value (Un\G86 to Un\G117) CH□ rate alarm warning detection period (Un\G118 to Un\G125) CH□ rate alarm upper/lower limit value (Un\G126 to Un\G141) CH□ input signal error detection setting value (Un\G142 to Un\G149) Refer to the input X9 column for ON/OFF timing.
YD	Maximum value/minimum value reset request	<ul style="list-style-type: none"> Turning ON the Maximum value/minimum value reset request (YD) clears the maximum value/minimum value stored at any of the buffer memory addresses 30 to 45 (Un\G30 to Un\G45). Refer to the input XD column for ON/OFF timing.
YF	Error clear request	<ul style="list-style-type: none"> Turn this signal ON when clearing a write error or input signal error. Refer to the field of XF or XC for the ON/OFF timing.

Tab. 3-9: Detailed description of the output signals (Signal direction CPU Module → ME1AD8HAI-Q)

3.5 Buffer Memory

The HART analog input module has a memory range assigned as a buffer for temporary storage of data, such as analog measurement values or HART device data. The PLC CPU can access this buffer and both read the stored values from it and write new values to it which the module can then process (settings for the module's functions etc).

Each buffer memory address consists of 16 bits.

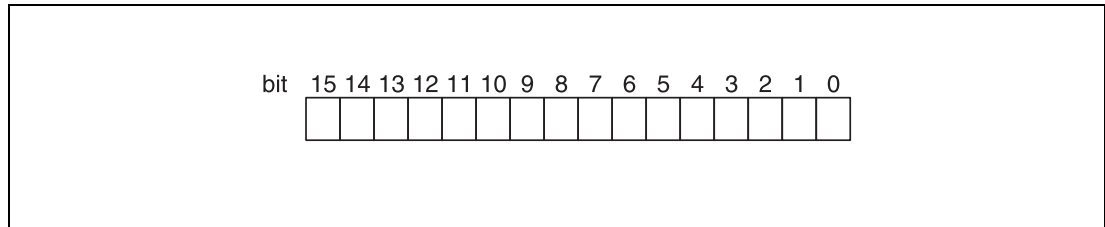

Fig. 3-14: Assignments of bits to a buffer memory address

NOTE

Do not write data in the "system areas" of the buffer memory. If data is written to any of the system areas, the PLC system may not be operated properly. Some of the user areas contain partially system areas. Care must be taken when reading/writing to the buffer memory. Also, do not write data (e.g. in a sequence program) to the buffer memory area where writing is disabled. Doing so may cause malfunction.

Instructions for data exchange with the buffer memory

Communication between the PLC CPU and the buffer memory of special function modules is performed with FROM and TO instructions.

The buffer memory of a special function module can also be accessed directly, e.g. with a MOV instruction. The special function module addressed in this way can be mounted on a base unit or an extension base unit but not in remote I/O stations.

Format of the device address: Un\Gn

- Un: Head address of the special function module
- Gn: Buffer memory address (decimal)

For example the device address U3\G11 designates the buffer memory address 11 in the special function module with the head address 3 (X/Y30 to X/Y3F).

In this User's Manual the latter form of addressing is used throughout.

For full documentation of all the instructions with examples please refer to the Programming Manual for the A/Q series and the MELSEC System Q, art. no. 87431.

3.5.1 Buffer memory assignment

Address		Description	Default	R/W*1	Reference
Hexa-decimal	Decimal				
0H	0	A/D conversion enable/disable setting	0000H	R/W*2	Section 3.5.2
1H	1	CH1	0	R/W*2	Section 3.5.3
2H	2	CH2			
3H	3	CH3			
4H	4	CH4			
5H	5	CH5			
6H	6	CH6			
7H	7	CH7			
8H	8	CH8			
9H	9	System area	—	—	—
AH	10	A/D conversion completed flag	0	R	Section 3.5.4
BH	11	CH1 Digital output value	0	R	Section 3.5.5
CH	12	CH2 Digital output value			
DH	13	CH3 Digital output value			
EH	14	CH4 Digital output value			
FH	15	CH5 Digital output value			
10H	16	CH6 Digital output value			
11H	17	CH7 Digital output value			
12H	18	CH8 Digital output value			
13H	19	Error code	0	R	Section 3.5.6
14H	20	Setting range (CH1 to CH4)	0	R	Section 3.5.7
15H	21	Setting range (CH5 to CH8)			
16H	22	System area	—	—	—
17H	23				
18H	24	Averaging process specification (CH1 to CH4)	0	R/W*2	Section 3.5.8
19H	25	Averaging process specification (CH5 to CH8)			

Tab. 3-10: Buffer memory assignment of ME1AD8HAI-Q (1/16)

*1 Indicates whether reading from and writing to a sequence program are enabled.

R : Read enabled

W : Write enabled

*2 When writing data to the buffer memory, always use the interlock condition (buffer memory write condition) of the following I/O signals.



Address		Description	Default	R/W*1	Reference			
Hexa-decimal	Decimal							
1A _H	26	System area	—	—	—			
to	to							
1D _H	29							
1E _H	30	CH1	0	R	Section 3.5.9			
						Maximum value		
1F _H	31							
		Minimum value						
20 _H	32	CH2	0	R	Section 3.5.9			
						Maximum value		
21 _H	33							
		Minimum value						
22 _H	34	CH3	0	R	Section 3.5.9			
						Maximum value		
23 _H	35							
		Minimum value						
24 _H	36	CH4	0	R	Section 3.5.9			
						Maximum value		
25 _H	37							
		Minimum value						
26 _H	38	CH5	0	R	Section 3.5.9			
						Maximum value		
27 _H	39							
		Minimum value						
28 _H	40	CH6	0	R	Section 3.5.9			
						Maximum value		
29 _H	41							
		Minimum value						
2A _H	42	CH7	0	R	Section 3.5.9			
						Maximum value		
2B _H	43							
		Minimum value						
2C _H	44	CH8	0	R	Section 3.5.9			
						Maximum value		
2D _H	45							
		Minimum value						
2E _H	46	System area	—	—	—			
2F _H	47	Input signal error detection setting	00FF _H	R/W*2	Section 3.5.10			
30 _H	48	Warning output setting	FFFF _H	R/W*2	Section 3.5.11			
31 _H	49	Input signal error detection flag	0	R	Section 3.5.12			
32 _H	50	Warning output flag (Process alarm)	0	R	Section 3.5.13			
33 _H	51	Warning output flag (Rate alarm)						
34 _H	52	System area	—	—	—			
35 _H	53	Scaling enable/disable setting	00FF _H	R/W*2	Section 3.5.14			
36 _H	54	Scaling value	0	R	Section 3.5.15			
37 _H	55							
38 _H	56							
39 _H	57							
3A _H	58							
3B _H	59							
3C _H	60							
3D _H	61							
3E _H	62	CH1	Scaling	Lower limit value	0	R/W*2	Section 3.5.16	
				Upper limit value	0			
3F _H	63							
40 _H	64	CH2	Scaling	Lower limit value	0	R/W*2		Section 3.5.16
				Upper limit value	0			
41 _H	65							
42 _H	66	CH3	Scaling	Lower limit value	0	R/W*2	Section 3.5.16	
				Upper limit value	0			
43 _H	67							

Tab. 3-11: Buffer memory assignment of ME1AD8HAI-Q (2/16)

*1 Indicates whether reading from and writing to a sequence program are enabled.

R : Read enabled
W : Write enabled

*2 When writing data to the buffer memory, always use the interlock condition (buffer memory write condition) of the following I/O signals.



Address		Description			Default	R/W*1	Reference
Hexa-decimal	Decimal						
44H	68	CH4	Scaling	Lower limit value	0	R/W*2	Section 3.5.16
45H	69			Upper limit value	0		
46H	70	CH5	Scaling	Lower limit value	0	R/W*2	
47H	71			Upper limit value	0		
48H	72	CH6	Scaling	Lower limit value	0	R/W*2	
49H	73			Upper limit value	0		
4AH	74	CH7	Scaling	Lower limit value	0	R/W*2	
4BH	75			Upper limit value	0		
4CH	76	CH8	Scaling	Lower limit value	0	R/W*2	
4DH	77			Upper limit value	0		
4EH	78	System area			—	—	—
to	to						
55H	85						
56H	86	CH1	Process alarm	Lower lower limit value	0	R/W*2	Section 3.5.17
57H	87			Lower upper limit value	0		
58H	88			Upper lower limit value	0		
59H	89			Upper upper limit value	0		
5AH	90	CH2	Process alarm	Lower lower limit value	0	R/W*2	Section 3.5.17
5BH	91			Lower upper limit value	0		
5CH	92			Upper lower limit value	0		
5DH	93			Upper upper limit value	0		
5EH	94	CH3	Process alarm	Lower lower limit value	0	R/W*2	Section 3.5.17
5FH	95			Lower upper limit value	0		
60H	96			Upper lower limit value	0		
61H	97			Upper upper limit value	0		
62H	98	CH4	Process alarm	Lower lower limit value	0	R/W*2	Section 3.5.17
63H	99			Lower upper limit value	0		
64H	100			Upper lower limit value	0		
65H	101			Upper upper limit value	0		
66H	102	CH5	Process alarm	Lower lower limit value	0	R/W*2	Section 3.5.17
67H	103			Lower upper limit value	0		
68H	104			Upper lower limit value	0		
69H	105			Upper upper limit value	0		
6AH	106	CH6	Process alarm	Lower lower limit value	0	R/W*2	Section 3.5.17
6BH	107			Lower upper limit value	0		
6CH	108			Upper lower limit value	0		
6DH	109			Upper upper limit value	0		
6EH	110	CH7	Process alarm	Lower lower limit value	0	R/W*2	Section 3.5.17
6FH	111			Lower upper limit value	0		
70H	112			Upper lower limit value	0		
71H	113			Upper upper limit value	0		

Tab. 3-12: Buffer memory assignment of ME1AD8HAI-Q (3/16)

*1 Indicates whether reading from and writing to a sequence program are enabled.

R : Read enabled
W : Write enabled

*2 When writing data to the buffer memory, always use the interlock condition (buffer memory write condition) of the following I/O signals.



Address		Description	Default	R/W*1	Reference		
Hexa-decimal	Decimal						
72H	114	CH8 Process alarm	Lower lower limit value	0	R/W*2	Section 3.5.17	
73H	115		Lower upper limit value	0			
74H	116		Upper lower limit value	0			
75H	117		Upper upper limit value	0			
76H	118	CH1	Rate alarm warning detection period		0	R/W*2	Section 3.5.18
77H	119	CH2					
78H	120	CH3					
79H	121	CH4					
7AH	122	CH5					
7BH	123	CH6					
7CH	124	CH7					
7DH	125	CH8					
7EH	126	CH1 Rate alarm	Upper limit value	0	R/W*2	Section 3.5.19	
7FH	127		Lower limit value	0			
80H	128	CH2 Rate alarm	Upper limit value	0	R/W*2		
81H	129		Lower limit value	0			
82H	130	CH3 Rate alarm	Upper limit value	0	R/W*2		
83H	131		Lower limit value	0			
84H	132	CH4 Rate alarm	Upper limit value	0	R/W*2		
85H	133		Lower limit value	0			
86H	134	CH5 Rate alarm	Upper limit value	0	R/W*2		
87H	135		Lower limit value	0			
88H	136	CH6 Rate alarm	Upper limit value	0	R/W*2		
89H	137		Lower limit value	0			
8AH	138	CH7 Rate alarm	Upper limit value	0	R/W*2		
8BH	139		Lower limit value	0			
8CH	140	CH8 Rate alarm	Upper limit value	0	R/W*2		
8DH	141		Lower limit value	0			
8EH	142	CH1-CH8 Input signal error detection setting value	50		R/W*2		Section 3.5.20
8FH	143						
90H	144						
91H	145						
92H	146						
93H	147						
94H	148						
95H	149						

Tab. 3-13: Buffer memory assignment of ME1AD8HAI-Q (4/16)

*1 Indicates whether reading from and writing to a sequence program are enabled.

R : Read enabled
W : Write enabled

*2 When writing data to the buffer memory, always use the interlock condition (buffer memory write condition) of the following I/O signals.



Address		Description	Default	R/W*1	Reference			
Hexa-decimal	Decimal							
96H	150	System area	—	—	—			
to	to							
9FH	159							
A0H	160	HART	0000H	R/W*2	Section 3.5.21			
A1H	161		0000H	R	Section 3.5.22			
A2H	162		0	R	Section 3.5.23			
A3H	163		0	R				
A4H	164		0	R				
A5H	165	System area	—	—	—			
to	to							
AFH	175							
B0H	176	CH1	3	R/W*2	Section 3.5.24			
B1H	177	CH2						
B2H	178	CH3						
B3H	179	CH4						
B4H	180	CH5						
B5H	181	CH6						
B6H	182	CH7						
B7H	183	CH8						
B8H	184	System area	—	—	—			
to	to							
BEH	190							
BFH	191	HART device information refresh interval [seconds]		30	R/W*2	Section 3.5.25		
C0H	192	System area	—	—	—			
to	to							
EFH	239							
F0H	240	CH1	HART field device status		0000H	R	Section 3.5.26	
F1H	241		HART extended field device status		0000H	R	Section 3.5.27	
F2H	242		HART device variable status	Primary value (PV), secondary value (SV)		0000H	R	Section 3.5.28
F3H	243			Tertiary value (TV), fourth value (FV)		0000H	R	
F4H	244		Process variable	Primary value (PV)	Low word	0000H	R	Section 3.5.29
F5H	245				High word	7FC0H		
F6H	246			Secondary value (SV)	Low word	0000H	R	
F7H	247				High word	7FC0H		
F8H	248			Tertiary value (TV)	Low word	0000H	R	
F9H	249				High word	7FC0H		
FAH	250			Fourth value (FV)	Low word	0000H	R	
FBH	251				High word	7FC0H		

Tab. 3-14: Buffer memory assignment of ME1AD8HAI-Q (5/16)

*1 Indicates whether reading from and writing to a sequence program are enabled.

R : Read enabled
W : Write enabled

*2 When writing data to the buffer memory, always use the interlock condition (buffer memory write condition) of the following I/O signals.



Address		Description	Default	R/W*1	Reference		
Hexa-decimal	Decimal						
FC _H	252	HART field device status	0000 _H	R	Section 3.5.26		
FD _H	253						
FE _H	254	HART device variable status	Primary value (PV), secondary value (SV)	R	Section 3.5.28		
FF _H	255		Tertiary value (TV), fourth value (FV)			0000 _H	
100 _H	256	Process variable	Primary value (PV)	Low word	0000 _H	R	Section 3.5.29
101 _H	257			High word	7FC0 _H		
102 _H	258		Secondary value (SV)	Low word	0000 _H	R	
103 _H	259			High word	7FC0 _H		
104 _H	260		Tertiary value (TV)	Low word	0000 _H	R	
105 _H	261			High word	7FC0 _H		
106 _H	262		Fourth value (FV)	Low word	0000 _H	R	
107 _H	263			High word	7FC0 _H		
108 _H	264	HART field device status	0000 _H	R	Section 3.5.26		
109 _H	265	HART extended field device status	0000 _H	R	Sec 3.5.27		
10A _H	266	HART device variable status	Primary value (PV), secondary value (SV)	R	Section 3.5.28		
10B _H	267		Tertiary value (TV), fourth value (FV)			0000 _H	
10C _H	268	Process variable	Primary value (PV)	Low word	0000 _H	R	Section 3.5.29
10D _H	269			High word	7FC0 _H		
10E _H	270		Secondary value (SV)	Low word	0000 _H	R	
10F _H	271			High word	7FC0 _H		
110 _H	272		Tertiary value (TV)	Low word	0000 _H	R	
111 _H	273			High word	7FC0 _H		
112 _H	274		Fourth value (FV)	Low word	0000 _H	R	
113 _H	275			High word	7FC0 _H		
114 _H	276	HART field device status	0000 _H	R	Section 3.5.26		
115 _H	277	HART extended field device status	0000 _H	R	Sec 3.5.27		
116 _H	278	HART device variable status	Primary value (PV), secondary value (SV)	R	Section 3.5.28		
117 _H	279		Tertiary value (TV), fourth value (FV)			0000 _H	
118 _H	280	Process variable	Primary value (PV)	Low word	0000 _H	R	Section 3.5.29
119 _H	281			High word	7FC0 _H		
11A _H	282		Secondary value (SV)	Low word	0000 _H	R	
11B _H	283			High word	7FC0 _H		
11C _H	284		Tertiary value (TV)	Low word	0000 _H	R	
11D _H	285			High word	7FC0 _H		
11E _H	286		Fourth value (FV)	Low word	0000 _H	R	
11F _H	287			High word	7FC0 _H		

Tab. 3-15: Buffer memory assignment of ME1AD8HAI-Q (6/16)

*1 Indicates whether reading from and writing to a sequence program are enabled.

R : Read enabled
W : Write enabled

*2 When writing data to the buffer memory, always use the interlock condition (buffer memory write condition) of the following I/O signals.



Address		Description	Default	R/W*1	Reference				
Hexa-decimal	Decimal								
120H	288	CH5	HART field device status		0000H	R	Section 3.5.26		
121H	289		HART extended field device status		0000H	R	Sec 3.5.27		
122H	290		HART device variable status	Primary value (PV), secondary value (SV)		0000H	R	Section 3.5.28	
123H	291			Tertiary value (TV), fourth value (FV)		0000H	R		
124H	292		Process variable	Primary value (PV)	Low word	0000H	R	Section 3.5.29	
125H	293				High word	7FC0H			
126H	294			Secondary value (SV)	Low word	0000H	R		
127H	295				High word	7FC0H			
128H	296			Tertiary value (TV)	Low word	0000H	R		
129H	297				High word	7FC0H			
12AH	298			Fourth value (FV)	Low word	0000H	R		
12BH	299				High word	7FC0H			
12CH	300		CH6	HART field device status		0000H	R	Section 3.5.26	
12DH	301			HART extended field device status		0000H	R	Section 3.5.27	
12EH	302			HART device variable status	Primary value (PV), secondary value (SV)		0000H	R	Section 3.5.28
12FH	303				Tertiary value (TV), fourth value (FV)		0000H	R	
130H	304	Process variable		Primary value (PV)	Low word	0000H	R	Section 3.5.29	
131H	305				High word	7FC0H			
132H	306			Secondary value (SV)	Low word	0000H	R		
133H	307				High word	7FC0H			
134H	308			Tertiary value (TV)	Low word	0000H	R		
135H	309				High word	7FC0H			
136H	310			Fourth value (FV)	Low word	0000H	R		
137H	311				High word	7FC0H			
138H	312	CH7		HART field device status		0000H	R	Section 3.5.26	
139H	313			HART extended field device status		0000H	R	Sec 3.5.27	
13AH	314			HART device variable status	Primary value (PV), secondary value (SV)		0000H	R	Section 3.5.28
13BH	315				Tertiary value (TV), fourth value (FV)		0000H	R	
13CH	316		Process variable	Primary value (PV)	Low word	0000H	R	Section 3.5.29	
13DH	317				High word	7FC0H			
13EH	318			Secondary value (SV)	Low word	0000H	R		
13FH	319				High word	7FC0H			
140H	320			Tertiary value (TV)	Low word	0000H	R		
141H	321				High word	7FC0H			
142H	322			Fourth value (FV)	Low word	0000H	R		
143H	323				High word	7FC0H			

Tab. 3-16: Buffer memory assignment of ME1AD8HAI-Q (7/16)

*1 Indicates whether reading from and writing to a sequence program are enabled.

R : Read enabled
W : Write enabled

*2 When writing data to the buffer memory, always use the interlock condition (buffer memory write condition) of the following I/O signals.



Address		Description	Default	R/W*1	Reference		
Hexa-decimal	Decimal						
144H	324	HART field device status	0000H	R	Section 3.5.26		
145H	325		HART extended field device status	0000H	R	Section 3.5.27	
146H	326	HART device variable status	Primary value (PV), secondary value (SV)	0000H	R	Section 3.5.28	
147H	327		Tertiary value (TV), fourth value (FV)	0000H	R		
148H	328	CH8 Process variable	Primary value (PV)	Low word	0000H	R	Section 3.5.29
149H	329			High word	7FC0H		
14AH	330		Secondary value (SV)	Low word	0000H	R	
14BH	331			High word	7FC0H		
14CH	332		Tertiary value (TV)	Low word	0000H	R	
14DH	333			High word	7FC0H		
14EH	334		Fourth value (FV)	Low word	0000H	R	
14FH	335			High word	7FC0H		
150H	336	System area	—	—	—		
to	to						
15FH	351						
160H	352	HART Command (Request)	Request flag	0	R/W*2	Section 3.5.30	
161H	353		Channel	0000H			
162H	354		Code	0000H			
163H	355		Data size	0			
164H	356		Data to be sent	0	R/W*2		
to	to						
1E3H	483	System area	—	—	—		
1E4H	484						
1EFH	495						
1F0H	496	HART Command (Answer)	Answer flag	0000H	R	Section 3.5.31	
1F1H	497		Channel	0000H			
1F2H	498		Code	0000H			
1F3H	499		Data size	0			
1F4H	500		Received data	0	R		
to	to						
273H	627	System area	—	—	—		
274H	628						
to	to						
37FH	895						

Tab. 3-17: Buffer memory assignment of ME1AD8HAI-Q (8/16)

*1 Indicates whether reading from and writing to a sequence program are enabled.

R : Read enabled
W : Write enabled

*2 When writing data to the buffer memory, always use the interlock condition (buffer memory write condition) of the following I/O signals.



Address		Description	Default	R/W*1	Reference	
Hexa-decimal	Decimal					
380H	896	CH1 Information about HART device	0000H	R	Section 3.5.32	
to	to					
383H	899					Tag
384H	900					Message
to	to					
393H	915					Descriptor
394H	916					
39B _H	923					Manufacturer ID / Expanded manufacturer ID (HART 7)
39C _H	924					
39D _H	925					Device Type / Expanded device type (HART 7)
39E _H	926					Device ID
39F _H	927					
3A0 _H	928					Revisions
3A1 _H	929					
3A2 _H	930					Device function flags
3A3 _H	931					
to	to					Long tag
3B2 _H	946					
3B3 _H	947					Private label distributor code (HART 7)
3B4 _H	948					Device profile (HART 7)
3B5 _H	949	System area	—	—	—	
3B6 _H	950	CH1 Information about HART device	0000H	R	Section 3.5.32	
3B7 _H	951					Final assembly number
3B8 _H	952					Date
3B9 _H	953					Write Protect
3BA _H	954					
3BB _H	955					PV range unit code
3BC _H	956					PV Upper range value
3BD _H	957					PV Lower range value
3BE _H	958					
3BF _H	959					PV Damping value
3C0 _H	960					Transfer function
3C1 _H	961					
3C2 _H	962					PV Unit code
3C3 _H	963					SV Unit code
3C4 _H	964	TV Unit code				
3C5 _H	965	FV Unit code				
3C6 _H	966	0000H				
3C7 _H	967	System area	—	—	—	

Tab. 3-18: Buffer memory assignment of ME1AD8HAI-Q (9/16)

*1 Indicates whether reading from and writing to a sequence program are enabled.

R : Read enabled
W : Write enabled

*2 When writing data to the buffer memory, always use the interlock condition (buffer memory write condition) of the following I/O signals.



Address		Description	Default	R/W*1	Reference	
Hexa-decimal	Decimal					
3C8 _H	968	CH2 Information about HART device	0000 _H	R	Section 3.5.32	
to	to					
3CB _H	971					Tag
3CC _H	972					Message
to	to					
3DB _H	987					Descriptor
3DC _H	988					
to	to					Manufacturer ID / Expanded manufacturer ID (HART 7)
3E3 _H	995					
3E4 _H	996					Device Type / Expanded device type (HART 7)
3E5 _H	997					
3E6 _H	998					Device ID
3E7 _H	999					
3E8 _H	1000					Revisions
3E9 _H	1001					
3EA _H	1002					Device function flags
3EB _H	1003					
to	to					Long tag
3FA _H	1018					
3FB _H	1019					Private label distributor code (HART 7)
3FC _H	1020	Device profile (HART 7)				
3FD _H	1021	System area	—	—	—	
3FE _H	1022	CH2 Information about HART device	0000 _H	R	Section 3.5.32	
3FF _H	1023					Final assembly number
400 _H	1024					Date
401 _H	1025					Write Protect
402 _H	1026					PV range unit code
403 _H	1027					PV Upper range value
404 _H	1028					
405 _H	1029					PV Lower range value
406 _H	1030					
407 _H	1031					PV Damping value
408 _H	1032					
409 _H	1033					Transfer function
40A _H	1034					
40B _H	1035					PV Unit code
40C _H	1036					SV Unit code
40D _H	1037	TV Unit code				
40E _H	1038	FV Unit code				
40F _H	1039	System area	—	—	—	

Tab. 3-19: Buffer memory assignment of ME1AD8HAI-Q (10/16)

*1 Indicates whether reading from and writing to a sequence program are enabled.

R : Read enabled
W : Write enabled

*2 When writing data to the buffer memory, always use the interlock condition (buffer memory write condition) of the following I/O signals.



Address		Description	Default	R/W*1	Reference	
Hexa-decimal	Decimal					
410H	1040	CH3 Information about HART device	0000H	R	Section 3.5.32	
to	to					Tag
413H	1043					Message
414H	1044					
to	to					
423H	1059					Descriptor
424H	1060					
to	to					
42BH	1067					Manufacturer ID / Expanded manufacturer ID (HART 7)
42CH	1068					
42DH	1069					Device Type / Expanded device type (HART 7)
42EH	1070					
42FH	1071					Device ID
430H	1072					
431H	1073					Revisions
432H	1074					
433H	1075					Device function flags
to	to					
442H	1090					Long tag
443H	1091					
444H	1092	Private label distributor code (HART 7)				
		Device profile (HART 7)				
445H	1093	System area	—	—	—	
446H	1094	CH3 Information about HART device	0000H	R	Section 3.5.32	
447H	1095					Final assembly number
448H	1096					Date
449H	1097					
44AH	1098					Write Protect
44BH	1099					PV range unit code
44CH	1100					PV Upper range value
44DH	1101					
44EH	1102					PV Lower range value
44FH	1103					
450H	1104					PV Damping value
451H	1105					
452H	1106					Transfer function
453H	1107					PV Unit code
454H	1108	SV Unit code				
455H	1109	TV Unit code				
456H	1110	FV Unit code				
457H	1111	System area	—	—	—	

Tab. 3-20: Buffer memory assignment of ME1AD8HAI-Q (11/16)

*1 Indicates whether reading from and writing to a sequence program are enabled.

R : Read enabled
W : Write enabled

*2 When writing data to the buffer memory, always use the interlock condition (buffer memory write condition) of the following I/O signals.



Address		Description	Default	R/W*1	Reference	
Hexa-decimal	Decimal					
458H	1112	CH4 Information about HART device	0000H	R	Section 3.5.32	
to	to					
45BH	1115					Tag
45CH	1116					Message
to	to					
46BH	1131					Descriptor
46CH	1132					
to	to					Manufacturer ID / Expanded manufacturer ID (HART 7)
473H	1139					
474H	1140					Device Type / Expanded device type (HART 7)
475H	1141					
476H	1142					Device ID
477H	1143					
478H	1144					Revisions
479H	1145					
47AH	1146					Device function flags
47BH	1147					
to	to					Long tag
48AH	1162					
48BH	1163					Private label distributor code (HART 7)
48CH	1164	Device profile (HART 7)				
48DH	1165	System area	—	—	—	
48EH	1166	CH4 Information about HART device	0000H	R	Section 3.5.32	
48FH	1167					Final assembly number
490H	1168					Date
491H	1169					Write Protect
492H	1170					
493H	1171					PV range unit code
494H	1172					PV Upper range value
495H	1173					
496H	1174					PV Lower range value
497H	1175					PV Damping value
498H	1176					
499H	1177					Transfer function
49AH	1178					
49BH	1179					PV Unit code
49CH	1180	SV Unit code				
49DH	1181	TV Unit code				
49EH	1182	FV Unit code				
49FH	1183	System area	—	—	—	

Tab. 3-21: Buffer memory assignment of ME1AD8HAI-Q (12/16)

*1 Indicates whether reading from and writing to a sequence program are enabled.

R : Read enabled
W : Write enabled

*2 When writing data to the buffer memory, always use the interlock condition (buffer memory write condition) of the following I/O signals.



Address		Description	Default	R/W*1	Reference	
Hexa-decimal	Decimal					
4A0H	1184	CH5 Information about HART device	0000H	R	Section 3.5.32	
to	to					
4A3H	1187					Tag
4A4H	1188					Message
4B3H	1203					Descriptor
4B4H	1204					Manufacturer ID / Expanded manufacturer ID (HART 7)
4BBH	1211					Device Type / Expanded device type (HART 7)
4BCH	1212					Device ID
4BDH	1213					Revisions
4BEH	1214					Device function flags
4BFH	1215					Long tag
4C0H	1216					Private label distributor code (HART 7)
4C1H	1217					Device profile (HART 7)
4C2	1218					
4C3H	1219					
to	to					
4D2H	1234					
4D3H	1235					
4D4H	1236					
4D5H	1237					System area
4D6H	1238	CH5 Information about HART device	0000H	R	Section 3.5.32	
4D7H	1239					Final assembly number
4D8H	1240					Date
4D9H	1241					Write Protect
4DAH	1242					PV range unit code
4DBH	1243					PV Upper range value
4DCH	1244					PV Lower range value
4DDH	1245					PV Damping value
4DEH	1246					Transfer function
4DFH	1247					PV Unit code
4E0H	1248					SV Unit code
4E1H	1249					TV Unit code
4E2H	1250					FV Unit code
4E3H	1251					
4E4H	1252					
4E5H	1253					
4E6H	1254					
4E7H	1255	System area	—	—	—	

Tab. 3-22: Buffer memory assignment of ME1AD8HAI-Q (13/16)

*1 Indicates whether reading from and writing to a sequence program are enabled.

R : Read enabled
W : Write enabled

*2 When writing data to the buffer memory, always use the interlock condition (buffer memory write condition) of the following I/O signals.



Address		Description	Default	R/W*1	Reference				
Hexa-decimal	Decimal								
4E8H	1256	CH6 Information about HART device	0000H	R	Section 3.5.32				
to	to								
4EBH	1259					Tag			
4ECH	1260					Message			
to	to								
4FBH	1275					Descriptor			
4FCH	1276								
503H	1283					Manufacturer ID / Expanded manufacturer ID (HART 7)			
504H	1284								
505H	1285					Device Type / Expanded device type (HART 7)			
506H	1286					Device ID			
507H	1287								
508H	1288					Revisions			
509H	1289					Device function flags			
50AH	1290								
50BH	1291					Long tag			
to	to								
51AH	1306					Private label distributor code (HART 7)			
51BH	1307					Device profile (HART 7)			
51CH	1308					System area	—	—	—
51DH	1309	CH6 Information about HART device	0000H	R	Section 3.5.32				
51EH	1310					Final assembly number			
51FH	1311					Date			
520H	1312					Write Protect			
521H	1313					PV range unit code			
522H	1314					PV Upper range value			
523H	1315					PV Lower range value			
524H	1316					PV Damping value			
525H	1317					Transfer function			
526H	1318					PV Unit code			
527H	1319					SV Unit code			
528H	1320					TV Unit code			
529H	1321					FV Unit code			
52AH	1322					System area	—	—	—
52BH	1323								
52CH	1324								
52DH	1325								
52EH	1326								
52FH	1327								

Tab. 3-23: Buffer memory assignment of ME1AD8HAI-Q (14/16)

*1 Indicates whether reading from and writing to a sequence program are enabled.

R : Read enabled
W : Write enabled

*2 When writing data to the buffer memory, always use the interlock condition (buffer memory write condition) of the following I/O signals.



Address		Description	Default	R/W*1	Reference	
Hexa-decimal	Decimal					
530H	1328	CH7 Information about HART device	0000H	R	Section 3.5.32	
to	to					
533H	1331					Tag
534H	1332					Message
to	to					
543H	1347					Descriptor
544H	1348					
54B _H	1355					Device Type / Expanded device type (HART 7)
54C _H	1356					
54D _H	1357					Revisions
54E _H	1358					
54F _H	1359					Long tag
550 _H	1360					
551 _H	1361					Device profile (HART 7)
552 _H	1362					
553 _H	1363					System area
to	to					
562 _H	1378					System area
563 _H	1379					
564 _H	1380					System area
565 _H	1381	System area				
566 _H	1382		System area			
567 _H	1383	System area				
568 _H	1384		System area			
569 _H	1385	System area				
56A _H	1386		System area			
56B _H	1387	System area				
56C _H	1388		System area			
56D _H	1389	System area				
56E _H	1390		System area			
56F _H	1391	System area				
570 _H	1392		System area			
571 _H	1393	System area				
572 _H	1394		System area			
573 _H	1395	System area				
574 _H	1396		System area			
575 _H	1397	System area				
576 _H	1398		System area			
577 _H	1399	System area				

Tab. 3-24: Buffer memory assignment of ME1AD8HAI-Q (15/16)

*1 Indicates whether reading from and writing to a sequence program are enabled.

R : Read enabled
W : Write enabled

*2 When writing data to the buffer memory, always use the interlock condition (buffer memory write condition) of the following I/O signals.



Address		Description	Default	R/W*1	Reference		
Hexa-decimal	Decimal						
578 _H	1400	CH8 Information about HART device	0000 _H	R	Section 3.5.32		
to	to					Tag	
57B _H	1403					Message	
57C _H	1404						to
58B _H	1419						to
58C _H	1420					Descriptor	
to	to						to
593 _H	1427					Manufacturer ID / Expanded manufacturer ID (HART 7)	
594 _H	1428						to
595 _H	1429					Device Type / Expanded device type (HART 7)	
596 _H	1430					Device ID	
597 _H	1431						to
598 _H	1432					Revisions	
599 _H	1433						to
59A _H	1434					Device function flags	
59B _H	1435						to
to	to					Long tag	
5AA _H	1450						to
5AB _H	1451					Private label distributor code (HART 7)	
5AC _H	1452	Device profile (HART 7)					
5AD _H	1453	System area	—	—	—		
5AE _H	1454	CH8 Information about HART device	0000 _H	R	Section 3.5.32		
5AF _H	1455					Final assembly number	
5B0 _H	1456					Date	
5B1 _H	1457						to
5B2 _H	1458					Write Protect	
5B3 _H	1459					PV range unit code	
5B4 _H	1460					PV Upper range value	
5B5 _H	1461						to
5B6 _H	1462					PV Lower range value	
5B7 _H	1463					PV Damping value	
5B8 _H	1464						to
5B9 _H	1465					Transfer function	
5BA _H	1466						to
5BB _H	1467					PV Unit code	
5BC _H	1468	SV Unit code					
5BD _H	1469	TV Unit code					
5BE _H	1470	FV Unit code					
5BF _H	1471	System area	—	—	—		

Tab. 3-25: Buffer memory assignment of ME1AD8HAI-Q (16/16)

*1 Indicates whether reading from and writing to a sequence program are enabled.

R : Read enabled
W : Write enabled

*2 When writing data to the buffer memory, always use the interlock condition (buffer memory write condition) of the following I/O signals.



3.5.2 A/D conversion enable/disable setting (Un\G0)

- Set whether to enable or disable A/D conversion for each channel.
- It is necessary to set the operating condition setting request (Y9) to ON/OFF in order to validate the A/D conversion enable/disable setting. (Refer to section 3.4.2)
- The ME1AD8HAI-Q is preset to enable A/D conversion on all channels.

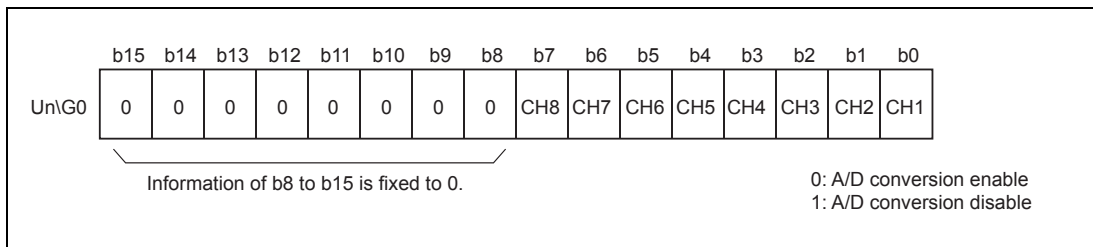

Fig. 3-15: Assignment of the bits in buffer memory address 0

Example: When channels for A/D conversion are 1 and 3, 00FAH is stored into Un\G0.

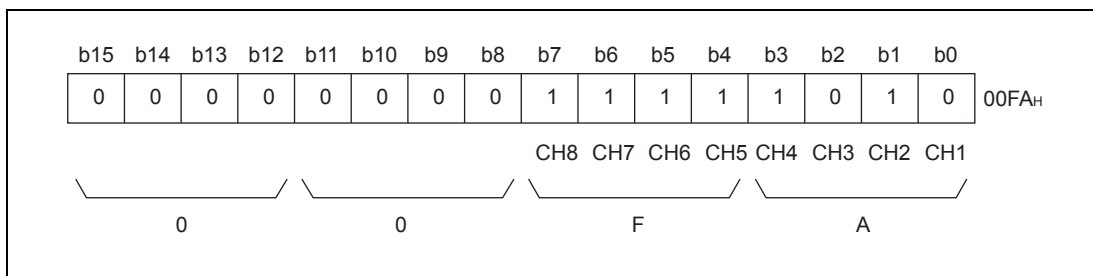

Fig. 3-16: In this example A/D conversion for the channels 1 and 3 is enabled.

3.5.3 CH□ Average time/Average number of times/Moving average/Time constant settings (Un\G1 to Un\G8)

- Set the average time, average count, moving average count or primary delay filter time constant for each channel for which averaging processing is specified.
- To validate the setting, the operating condition setting request (Y9) must be turned ON/OFF. (Refer to section 3.4.2)
- 0 is set as the default.

Processing method	Setting value
Time averaging	320 to 5000 (ms)
Count averaging	4 to 500 (times)
Moving average	2 to 60 (times)
Primary delay filter	80 to 5000 (ms)

Tab. 3-26: Setting ranges for processing

NOTES

Writing a value outside the range to a channel will cause an error, storing an error code in Error code (Un\G19) and turning ON the Error flag (XF). If this occurs, A/D conversion is performed based on the setting before the error detection.

Since the default setting is 0, change it for the selected processing method.

If a value is set to a sampling-processing channel, the value is ignored.

3.5.4 A/D conversion completed flag (Un\G10)

- When A/D conversion of a conversion-enabled channel is complete, the A/D conversion completed flag is set to 1.

The A/D conversion completed flag (XE) turns ON when conversion for all A/D-conversion-enabled channels is complete.

- When the operating condition setting request (Y9) is set to ON, the flag returns to the default setting of 0, and changes to 1 when A/D conversion is complete.

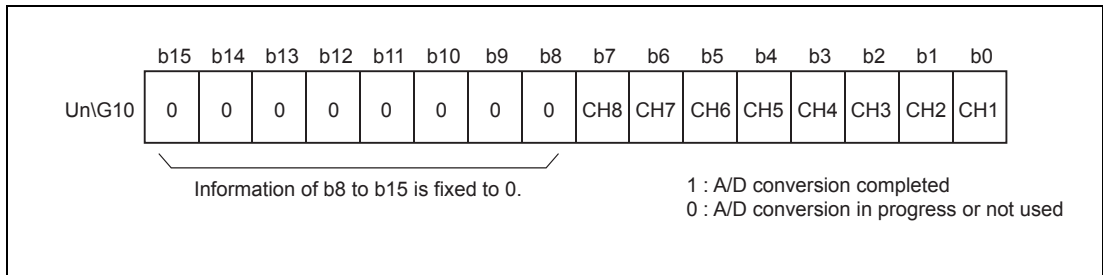

Fig. 3-17: Assignment of the bits in buffer memory address 10

- Example

When all A/D conversions of conversion-enabled channels 1 and 2 are completed, 0003H is stored into the buffer memory address 10 (Un\G10).

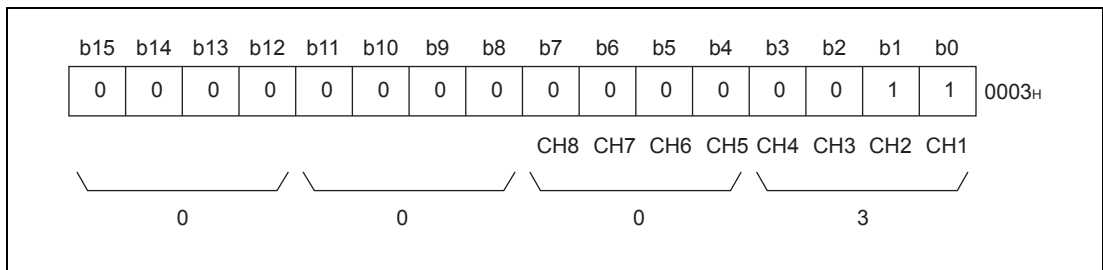

Fig. 3-18: A/D conversion of channels 1 and 2 is completed

3.5.5 CH□ digital output value (Un\G11 to Un\G18)

Digital values converted from analog values are stored for respective channels.

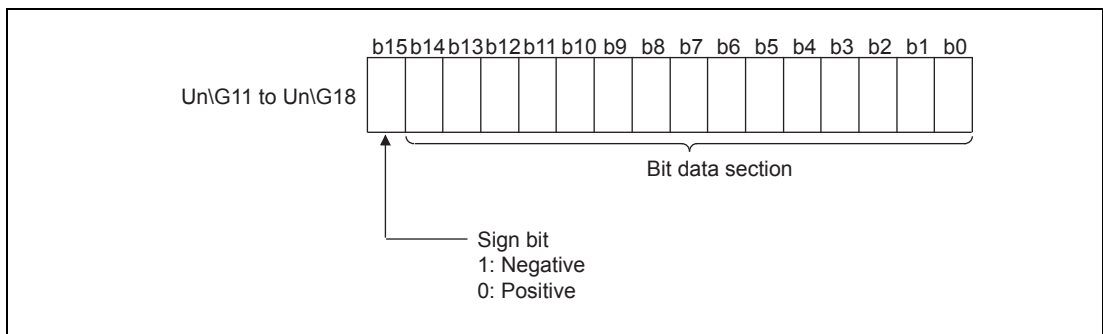

Fig. 3-19: Digital values are stored in 16-bit signed binary format

3.5.6 Write data error code (Un\G19)

An error code generated by the HART analog input module is stored here. Refer to section 6.1 for details of the error codes.

3.5.7 Setting range (Un\G20, Un\G21)

These areas are used to confirm the input ranges of respective channels. A value set in the input range setting is stored in the corresponding channel area as shown below.

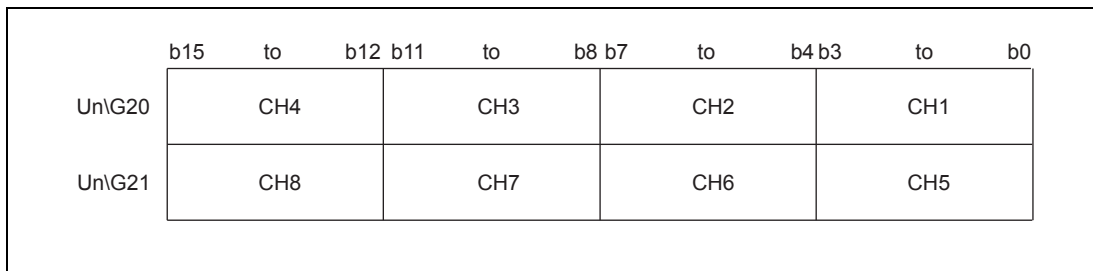

Fig. 3-20: Each buffer memory address stores the input setting range for four channels

The correlation between the input range and the settings in Un\G20 and Un\G21 is shown in the following table.

Input range	Setting value
4 to 20 (mA)	0H
0 to 20 (mA)	1H
Illegal (not allowed)	Other settings

Tab. 3-27: Input ranges of the ME1AD8HAI-Q

3.5.8 Averaging process specification (Un\G24, Un\G25)

- Specify whether to perform sampling processing or averaging processing (time averaging, count averaging, moving average, or primary delay filter) for each channel.
- To validate the setting, the operating condition setting request (Y9) must be turned ON/OFF. (Refer to section 3.4.2)
- By default, sampling processing(0H) is set for all channels.

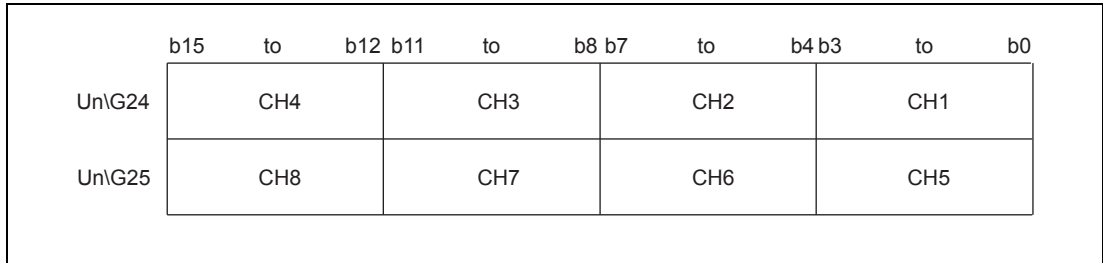

Fig. 3-21: Each buffer memory address stores the averaging process specification for four channels

The table below shows the correlation between the settings in Un\G24 and Un\G25 and the processing method.

Processing method	Setting value
Sampling processing	0H (Default)
Time averaging	1H
Count averaging	2H
Moving average	3H
Primary delay filter	4H

Tab. 3-28: Processing methods for the ME1AD8HAI-Q

● Example

When setting channel 1 to count averaging, channel 2 to time averaging, channel 3 to primary delay filter, and channel 4 to sampling processing, store 412_H into Un\G24.

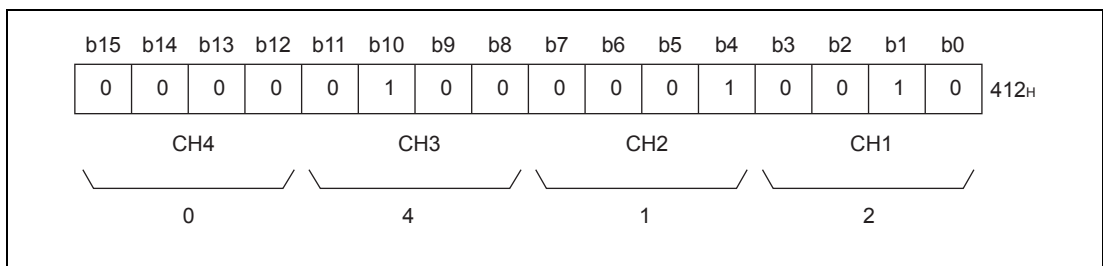

Fig. 3-22: Setting example for the channels 1 to 4 (Un\G24)

NOTE

When a value outside the above setting range has been written to a channel, sampling processing is applied to the channel.

3.5.9 CH□ maximum value/minimum value storage area (Un\G30 to Un\G45)

- The maximum value and minimum value of converted digital values are stored in 16-bit signed binary format for each channel.
- The stored values for all channels will be cleared to 0 when the operating condition setting request (Y9) is set to ON and the setting is changed or when the maximum value/minimum value reset request (YD) is set to ON.
- The maximum and minimum values are stored at intervals of the sample processing time, even if averaging processing is specified for the channel.
- When the scaling function is enabled, maximum/minimum values after scaling conversion are stored.

3.5.10 Input signal error detection setting (Un\G47)

- This area is used to set whether the input signal error detection will be enabled or disabled for each channel.
- To validate the input signal error detection setting, the operating condition setting request (Y9) must be turned ON/OFF. (Refer to section 3.4.2)
- All channels are set to disable as the default setting.

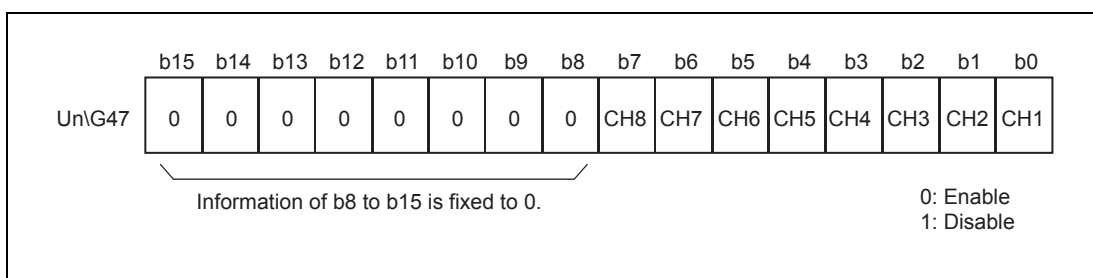

Fig. 3-23: Assignment of the bits in buffer memory address 47

● Example

To enable input signal error detection for channels 1 and 3, store 00FAH into Un\G47.

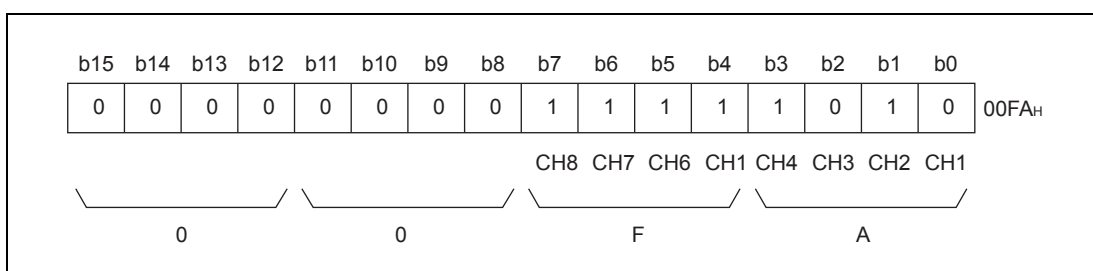

Fig. 3-24: Input signal error detection for channels 1 and 3 is enabled

3.5.11 Warning output settings (Un\G48)

- This area is used to set whether the process alarm/rate alarm warning is to be output or stopped on a channel basis.
- To validate the warning output setting, the operating condition setting request (Y9) must be turned ON/OFF. (Refer to section 3.4.2)
- By default, all channels are set to disable.

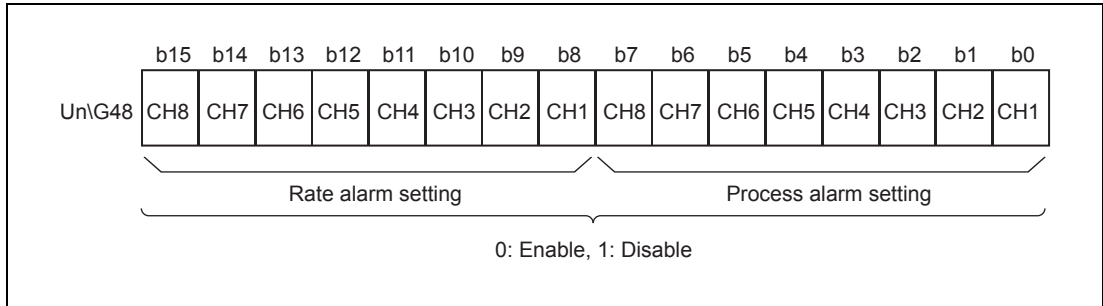

Fig. 3-25: Assignment of the bits in buffer memory address 48

- Example

When process alarm warning output is enabled for channel 7 and rate alarm warning output is enabled for channel 3, FBBFH is stored into Un\G48.

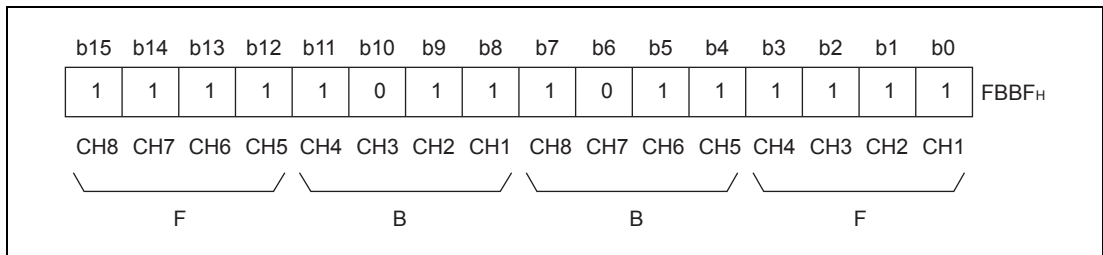

Fig. 3-26: Rate alarm warning output is enabled for channel 3
Process alarm warning output is enabled for channel 7

3.5.12 Input signal error detection flag (Un\G49)

- If the analog input value detected falls outside the setting range set to the CH□ input signal error detection setting value (Un\G142 to Un\G149), the Input signal error detection flag for the corresponding channel turns to 1.
- By bringing the analog input value within the setting range and turning ON the Error clear request (YF), the Input signal error detection flag turns OFF.
- If an error is detected on any one of the channels for which input signal error detection is enabled, the Input signal error detection signal (XC) also turns ON.
- When the operating condition setting request (Y9) is turned ON, the Input signal error detection flag is cleared.

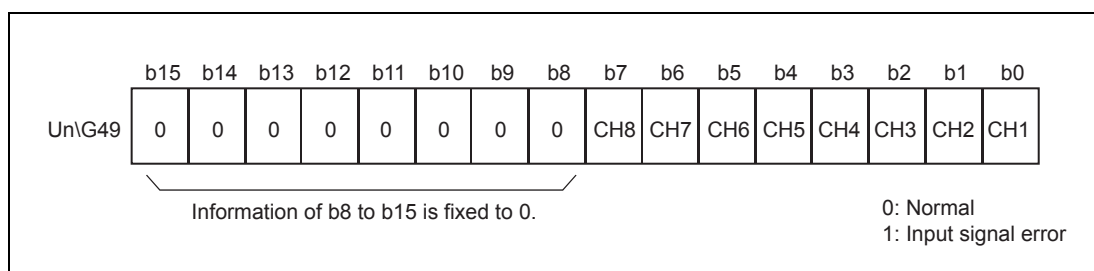

Fig. 3-27: Assignment of the bits in buffer memory address 49

3.5.13 Warning output flag (Un\G50, Un\G51)

- If the digital output value or its varying rate falls outside the setting range set in the following buffer memory addresses, the warning output flag for the corresponding channel turns to 1:
 - CH□ process alarm upper/lower limit value (Un\G86 to Un\G117)
 - CH□ rate alarm upper/lower limit value (Un\G126 to Un\G141)
- For both the process alarm and rate alarm, whether the warning is for the upper or lower limit value can be checked on a channel basis.
- When the digital output value or its varying rate returns to within the setting range, the warning output flag is automatically reset.
- If a warning is detected on any one of the channels for which A/D conversion and process alarm or rate alarm warning output are enabled, the Warning output signal (X8) also turns ON.
- When the operating condition setting request (Y9) is turned ON, the warning output flag is cleared.

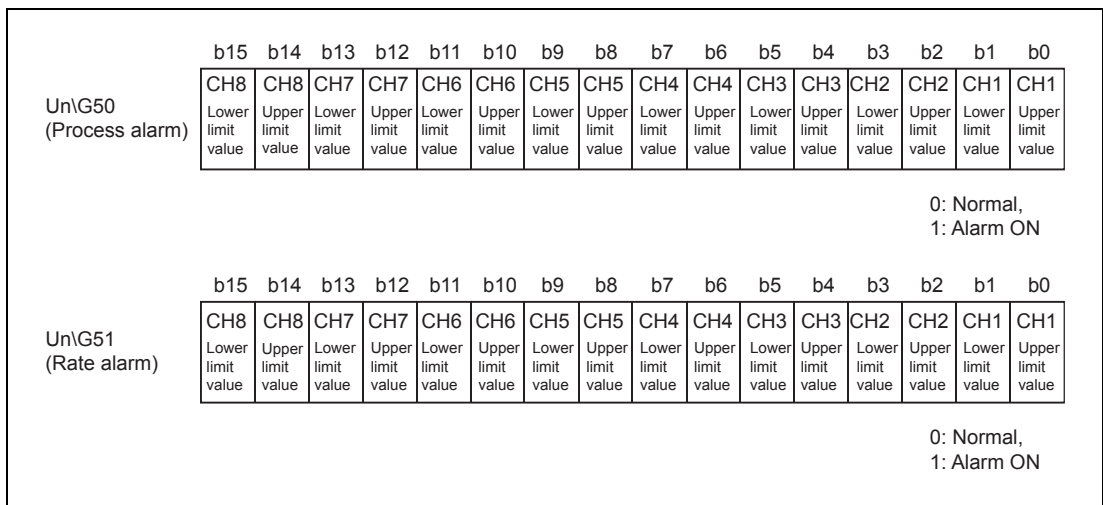

Fig. 3-28: For each channel two bits for upper and lower limit alarms are provided

3.5.14 Scaling enable/disable setting (Un\G53)

- Whether to enable or disable the scaling function for each channel is set in this area.
- To validate the scaling function, the operating condition setting request (Y9) must be turned ON/OFF. (Refer to section 3.4.2)
- All channels are defaulted to "Disable".

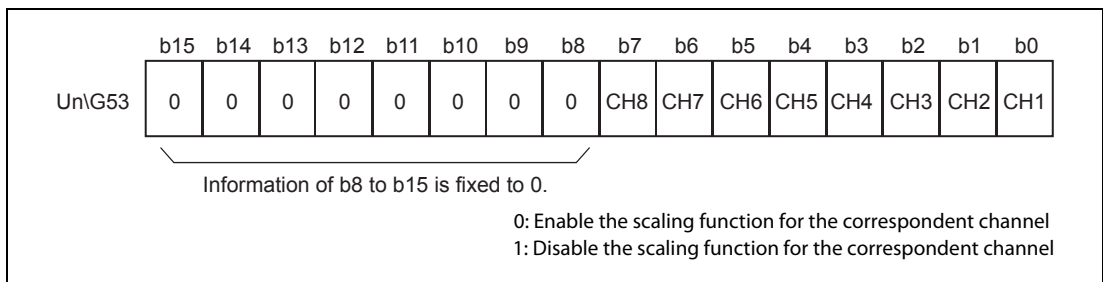

Fig. 3-29: Assignment of the bits in buffer memory address 53

NOTE When the Scaling enable/disable setting (Un\G53) is set to "Disable", 0s are stored in the CH□ scaling value storage area (Un\G54 to Un\G61).

3.5.15 CH□ scaling value storage area (Un\G54 to Un\G61)

- Digital output values after scaling conversion are stored for respective channels.
- Scaling conversion values are stored as 16-bit signed binaries.

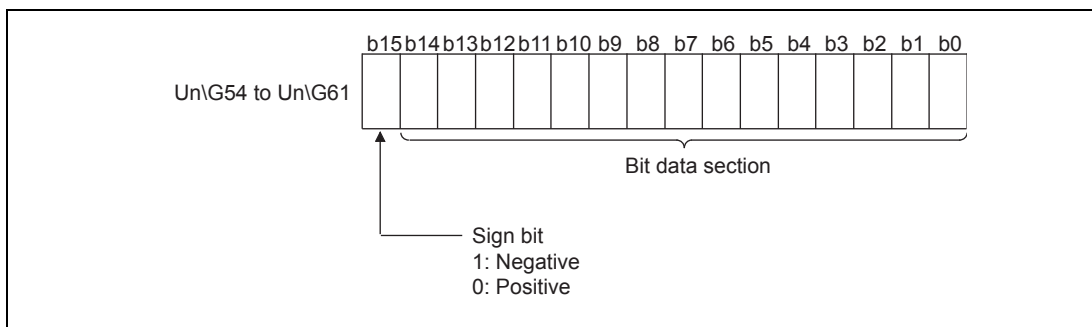

Fig. 3-30: Format of the scaling values

3.5.16 CH□ scaling upper/lower limit value (Un\G62 to Un\G77)

- Set a scaling conversion range for each channel.
- To validate the setting, the operating condition setting request (Y9) must be turned ON/OFF. (Refer to section 3.4.2)
- The setting range is -32000 to 32000.

Refer to section 3.3.5 for details of the scaling function.

NOTES

Setting a value outside the above setting range or a value that does not meet the inequality "Upper limit > Lower limit" will cause an error. If this occurs, an error code is stored in Error code (Un\G19) followed by ON of the Error flag (XF), and the module will operate under the setting before the error.

Since the default setting is 0, changing of the setting is required for operation.

When the Scaling enable/disable setting (Un\G53) is set to "Disable", scaling upper/lower limit values are ignored.

3.5.17 CH□ process alarm upper/lower limit value (Un\G86 to Un\G117)

- Set the range of the digital output value on a channel basis.
- To validate the setting, the operating condition setting request (Y9) must be turned ON/OFF. (Refer to section 3.4.2)
- The setting range is -32768 to 32767.
- Make four kinds of settings for process alarms:
 - upper upper limit value
 - upper lower limit value
 - lower upper limit value
 - lower lower limit value.
- Refer to section 3.3.4 for details of the process alarm.

NOTES

If a value outside the above setting range is set or if a value that does not satisfy the condition of "lower lower limit value \leq lower upper limit value \leq upper lower limit value \leq upper upper limit value" is set, it results in an error. An error code is stored into the Error code (Un\G19), the Error flag (XF) turns ON, and operation is performed based on the setting before the error detection.

Since the default setting is 0, changing of the setting is required for operation.

When "Enable" is set in the Scaling enable/disable setting (Un\G53), always take into account the scaling conversion before setting values.

3.5.18 CH□ rate alarm warning detection period (Un\G118 to Un\G125)

- Set a period, with which the varying rate of the digital output value will be checked, on a channel basis.
- To validate the setting, the operating condition setting request (Y9) must be turned ON/OFF. (Refer to section 3.4.2)
- The setting range is 80 to 5000 ms.
The value must be a multiple of the cycle time (80 ms)
- When time averaging or count averaging has been specified for averaging process specification, set the rate alarm warning detection period as a multiple of the time averaging or count averaging conversion period.

NOTE

If the count value set for the count averaging is 10, the conversion cycle for count averaging is:
 $10 \text{ (times)} \times 80 \text{ (ms)} = 800 \text{ (ms)}$
 Therefore, set a multiple of 800, such as 1600 or 3200, to the rate alarm warning detection period.

- The default setting is 0 ms.
- Refer to section 3.3.4 for details of the rate alarm.

NOTES

If a value outside the above setting range is written to a channel, an error occurs, and an error code is stored into the Error code (Un\G19). The Error flag (XF) turns ON, and the time or count averaging or rate alarm processing is performed based on the setting before the error detection.

Since the default setting is 0, changing of the setting is required for operation.

If the upper limit value and lower limit value settings of the rate alarm are small, the warning output may turn ON due to overreaction to disturbance or like. This overreaction can be avoided by increasing the setting of the rate alarm warning detection period.

3.5.19 CH□ rate alarm upper/lower limit value (Un\G126 to Un\G141)

- Set the varying rate range of the digital output value on a channel basis.
- To validate the setting, the operating condition setting request (Y9) must be turned ON/OFF. (Refer to section 3.4.2)
- The setting range is -32768 to 32767 (-3276.8 to 3276.7 %). Set the value in 0.1 %/s increments.
Example: When setting the rate alarm upper limit value to 30 % per second, store 300 into the buffer memory.
- Refer to section 3.3.4 for details of the rate alarm.

3.5.20 CH□ input signal error detection setting value (Un\G142 to Un\G149)

- Set the value, by which an error of the input analog value will be detected, on a channel basis.
- To validate the setting, the Operating condition setting request (Y9) must be turned ON/OFF. (Refer to section 3.4.2)
- The setting range is 0 to 250 (0 to 25.0 %). Set the value in 0.1 % increments.
Example: When setting the input signal error detection setting value to 15 %, store 150 into the buffer memory.
- Based on this input signal error detection setting value, the input signal upper and lower limit values are calculated as shown below. The calculated values vary depending on the input range.
 - Input signal error detection upper limit value
= gain value of corresponding range + (gain value of corresponding range - offset value of corresponding range) x (input signal error detection setting value /1000)
 - Input signal error detection lower limit value
= offset value of corresponding range - (gain value of corresponding range - offset value of corresponding range) x (input signal error detection setting value /1000)

NOTES

Set the input signal error detection upper limit value to less than 25 mA.
If the setting is 25 mA or more, the error may not be detected.

If a value outside the setting range is set, an error occurs and an error code is stored in the Error code (Un\G19). In this case, the operation is performed based on the setting before the error detection.

3.5.21 HART enable (Un\G160)

- After the bit corresponded to each channel is set, HART communication will be automatically started in the indicated channel.
- This setting is independent from the "A/D Conversion Enable/Disable" setting and the "Setting Range" setting. (The HART communication can be enabled or disabled even if the A/D conversion is disabled or the setting range is 0 to 20 mA.)

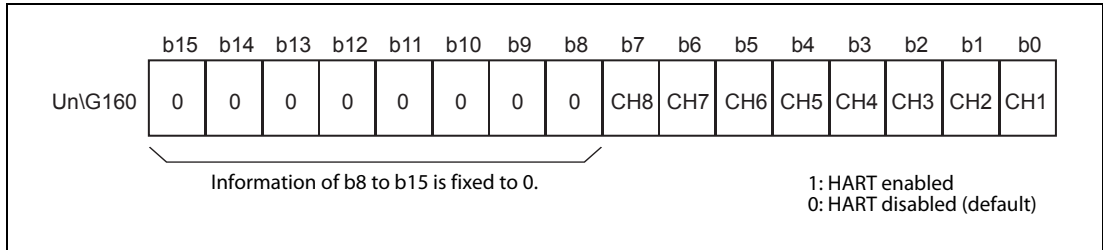

Fig. 3-31: Assignment of the bits in buffer memory address 160

3.5.22 HART scan list (Un\G161)

- After HART functionality is enabled, the ME1AD8HAI-Q will automatically detect the HART device which is connected with the enabled channel. After the device information are stored into the buffer memory, the corresponding bit in the "HART Scan list" is set. (Refer to the figures below.)

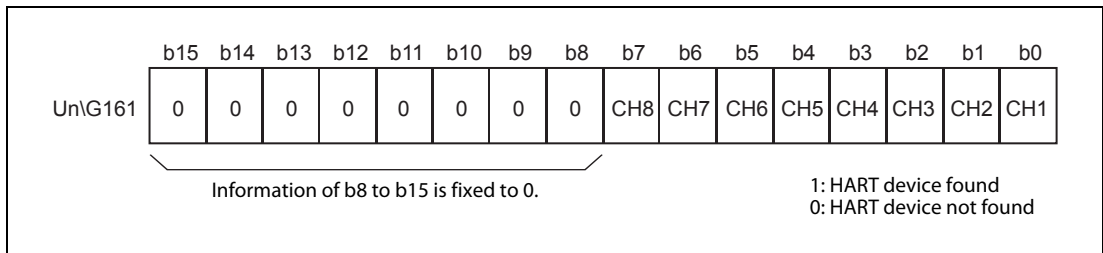

Fig. 3-32: Assignment of the bits in the HART scan list (buffer memory address 161)

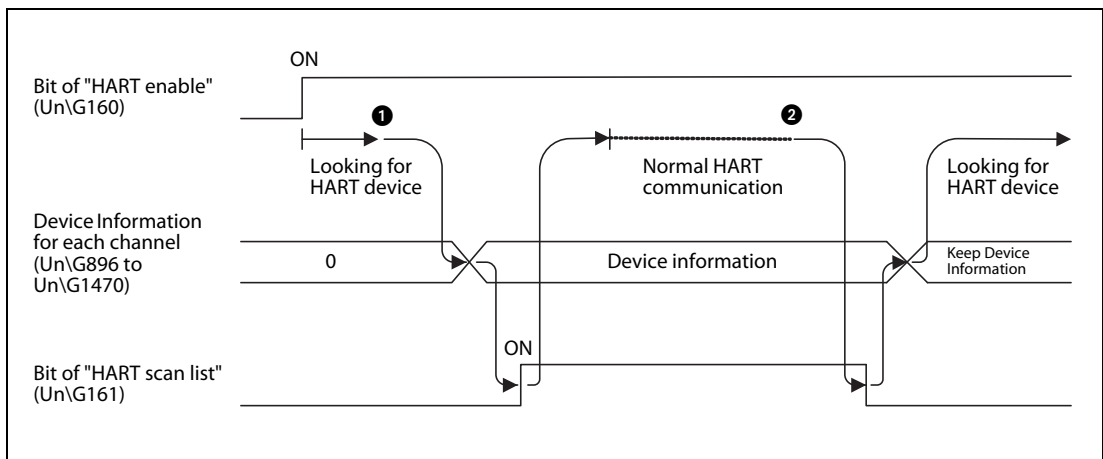

Fig. 3-33: Operation when HART device is detected and missing

- 1 When a HART device is detected, the device information is stored, the HART communication is initialized, and the corresponding bit in the HART scan list is set.
- 2 When the HART communication is interrupted due to a missing HART device, the corresponding bit in the HART scan list is reset and the HART device information is kept.

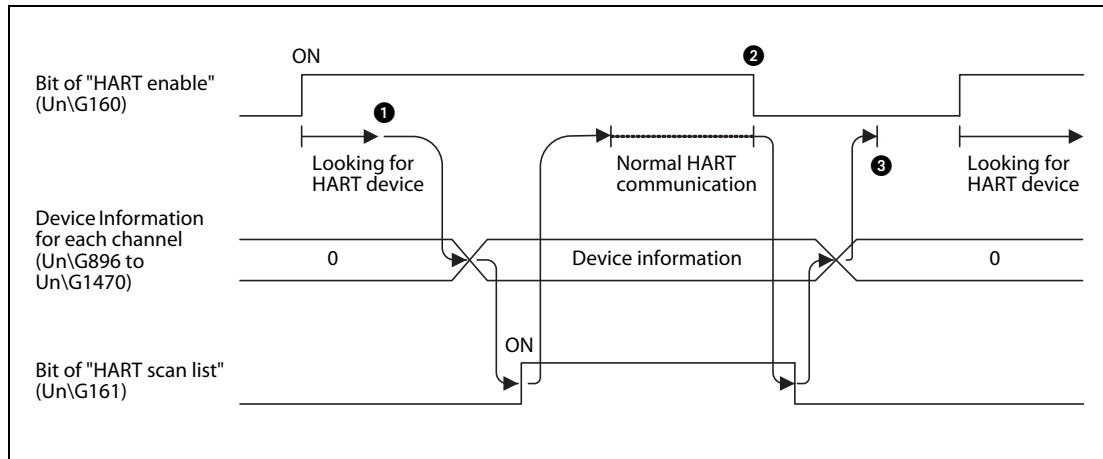

Fig. 3-34: Operation when HART functionality is disabled

- ❶ When a HART device is detected, the device information is stored, the HART communication is initialized, and the corresponding bit in the HART scan list is set.
- ❷ When the HART communication is disabled, the corresponding bit in the HART scan list is reset and the HART device information is cleared.
- ❸ Since the HART enable bit in Un\G160 is reset, the HART communication is stopped.

3.5.23 HART Cycle Time (Un\G162 to Un\G164)

- The current, maximum and minimum HART cycle time is stored in Un\G162, Un\G163 and Un\G164 respectively.
- The HART cycle time is the total time required for accessing each HART enabled channel or rather the time period between two accesses to the same HART channel.
- The unit of the HART cycle time is 10 ms.
- These values are reset after a power reset or PLC CPU reset.

3.5.24 HART Maximum Retries (Un\G176 to Un\G183)

- Set the maximum number of command retries for each HART channel.
- The range is 0 to 30, default is 3 retries.

3.5.25 HART device information refresh interval (Un\G191)

- Set the maximum interval in which the device information shall be read from a HART device.
- The range is 0 to 60 seconds, default is 30 seconds.
- This setting can speed up the FDT/DTM communication when changing configuration data via the DTM. The affected HART device information data is located in the buffer memory addresses Un\G896 to Un\G1470. The HART Process Variables (Un\G240 to Un\G335) are not affected, they are updated cyclically.

3.5.26 HART Field Device Status (Un\G240, Un\G252, Un\G264...)

Information about the status of the HART field device are stored in the corresponding buffer memory address (Channel 1: Un\G240, ch. 2: Un\252, ch3: Un\G264 etc.).

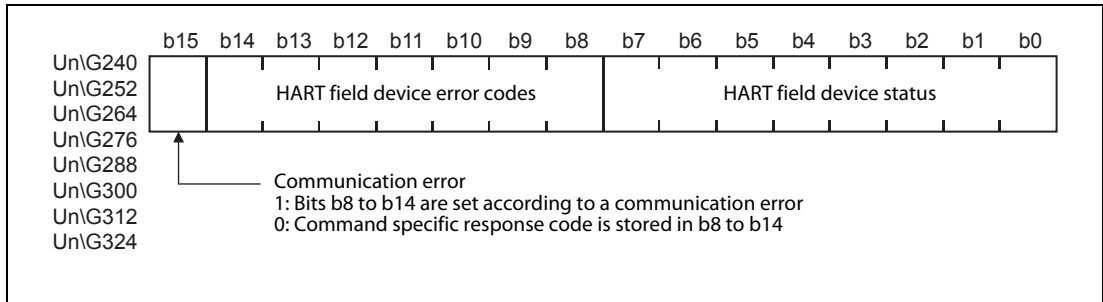

Fig. 3-35: Assignment of bits for HART field device error codes and status

The meaning of the bits b0 to b7 is as follows:

Bit	Meaning (when bit is set to "1")
b0	Primary variable out of limits
b1	Non-primary variable out of limits
b2	Loop current saturated
b3	Loop current fixed
b4	More status available
b5	Cold start
b6	Configuration changed
b7	Device malfunction

Tab. 3-29: HART field device status

Whether the bits b8 to b14 store information about a communication error or a command specific response code is indicated by b15:

Bit	When b15 is "1": Communication error	When b15 is "0": Command specific response code*
	Meaning (when bit is set to "1")	The code is the binary value of the bits b8 to b14.
b8	—	0: No error 5: Not enough data received 6: Device command error 7: Write protection 16: Access restricted 32: Device busy 64: Command not implemented
b9	Buffer overrun	
b10	—	
b11	Checksum error	
b12	Framing error	
b13	UART overrun	
b14	Parity error	

Tab. 3-30: HART field device error codes

* Listed in this table are some commonly used codes. For the codes available for the connected HART field device, please refer to the instruction manual of the device.

3.5.27 Extended HART Field Device Status (Un\G241, Un\G253, Un\G265...)

Information about the extended status of the HART field device are stored in the corresponding buffer memory address. (Channel 1: Un\G241, ch. 2: Un\253, ch3: Un\G265 etc.)

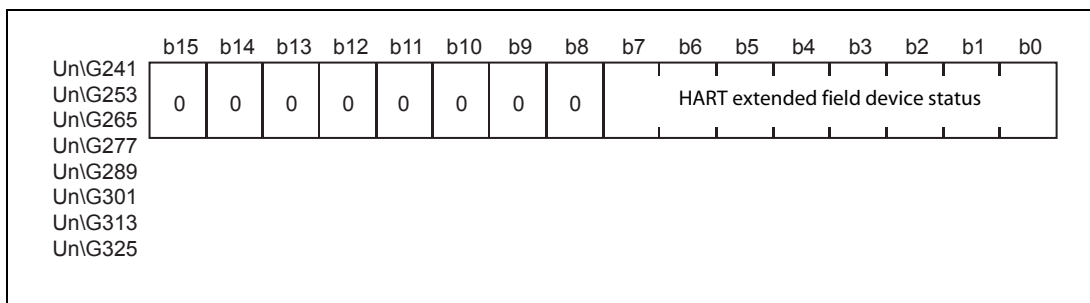

Fig. 3-36: Assignment of bits for HART extended field device status

The meaning of the bits b0 to b7 is as follows:

Bit	Meaning (when bit is set to "1")	Description
b0	Maintenance required	This bit is set to indicate that, while the device has not malfunctioned, the field device requires maintenance.
b1	Device variable alert	This bit is set if any device variable is in an alarm or warning state. The host should identify the device variable(s) causing this to be set using the device variable status indicators.
b2	Critical Power Failure	For devices that can operate from stored power. This bit is set when that power is becoming critically low. For example, a device powered by a rechargeable battery will set this bit if the battery voltage is becoming low. Devices must be able to sustain their network connection for at least 15 minutes from the moment when this bit is set. A device may disconnect from the network if its power level drops too low.
b3	—	—
b4	—	—
b5	—	—
b6	—	—
b7	—	—

Tab. 3-31: HART extended field device status

3.5.28 Device Variable Status (Un\G242 & Un\G243, Un\G254 & Un\G255...)

- The status of each HART device (process) variable according to the HART Command summary specification is stored in these buffer memory addresses.
- For each channel two buffer memory addresses are occupied.
- The Device Variable Status is read by HART command #9. If command #9 is not supported by the device, HART command #3 can be used instead. In this case the Device Variable Status is derived from the communication status ("Good" and "Bad" only).
- If a certain variable is not present in the device, the status is set to "bad".

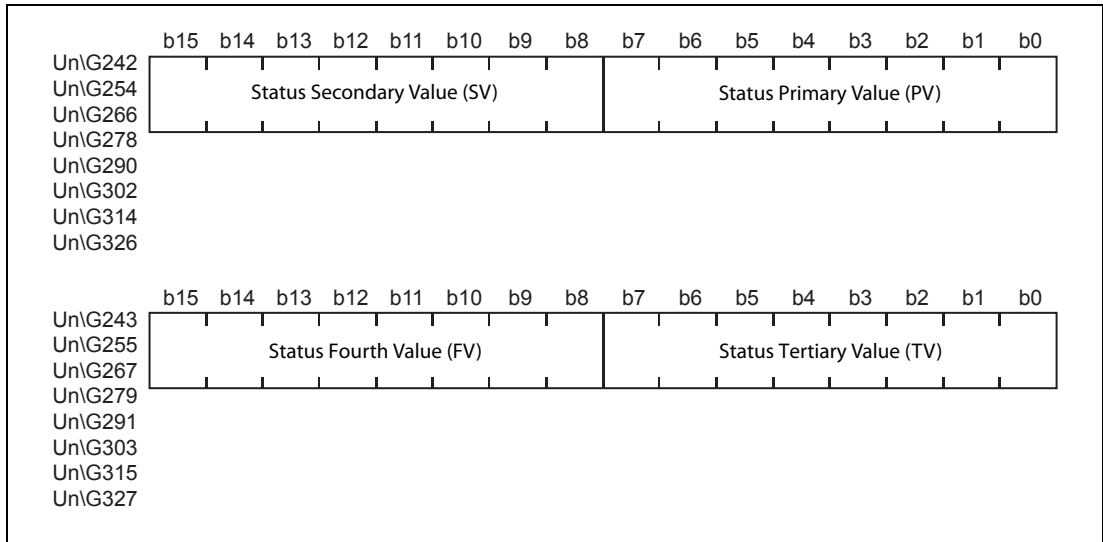

Fig. 3-37: The status of up to four device variables is stored

- Each status has the following structure.

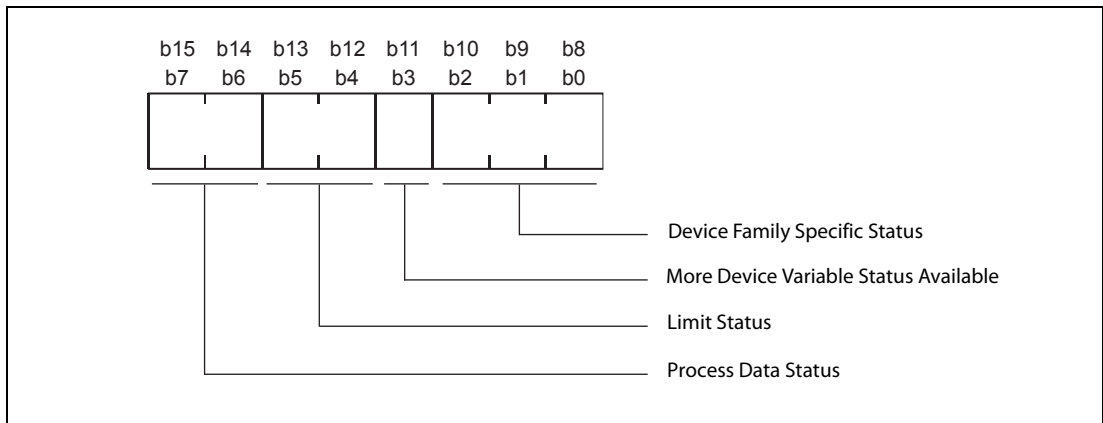

Fig. 3-38: Status structure

Item	Description	Remark
Device Family Specific Status	Device Family depended	—
More Device Variable Status Available	The availability of additional Device Family-specific status is stored. • 1 = More Device Variable Status available • 0 = More Device Variable Status not available	This bit indicates if the Device Family Specific Status is available via the Device Family Command.

Tab. 3-32: Contents of the Device Variable status

Item	Description	Remark
Limit Status	Shows whether the Device Variable value is limited. <ul style="list-style-type: none"> • 11 = Constant • 01 = Low Limited • 10 = High Limited • 00 = Not Limited 	The combinations of these 4 bits within each status show the status of Device Variable's value. For example, if the Process Data Status is "Manual/Fixed" and the Limit Status is "Not Limited" then the value is being manually controlled.
Process Data Status	The overall status of the Device or Dynamic Variable value is stored. <ul style="list-style-type: none"> • 11 = Good • 01 = Poor Accuracy • 10 = Manual/Fixed • 00 = Bad 	

Tab. 3-32: Contents of the Device Variable status

3.5.29 HART Process Variables (Un\G244 to Un\G251, Un\G256 to Un\G263...)

- The HART Devices variables as transmitted with command #9 or if not available with command #3.
- Up to four Process Variables are stored per channel.
- Each Process Variable occupies two successive buffer memory addresses. They are stored as 32-bit floating point numbers.
- If a certain variable is not present the corresponding buffer memory addresses are set to NaN (not a number) which is 7FC0000H.

NOTE

For a detailed description of floating point numbers please refer to the Programming Manual for the A/Q series and the MELSEC System Q, art. no. 87431.

3.5.30 HART Command Request (Un\G352 to Un\G483)

HART Command Request Flag (Un\G352)

- For execution of a HART command, the HART Command Request Flag is set to "1".
- Set the HART Command, the contents of the data buffer and data size before setting this flag.
- When the HART Command Answer Flag is "1" the HART Command Request Flag shall be reset.

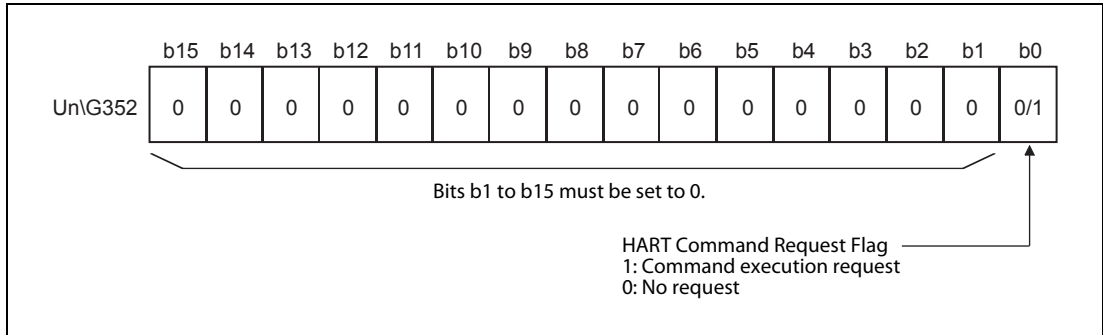

Fig. 3-39: Bit 0 of the buffer memory address Un\G352 is the request flag for a HART Command

The operation for a HART Command Request and the appropriate answer is shown in the following figure.

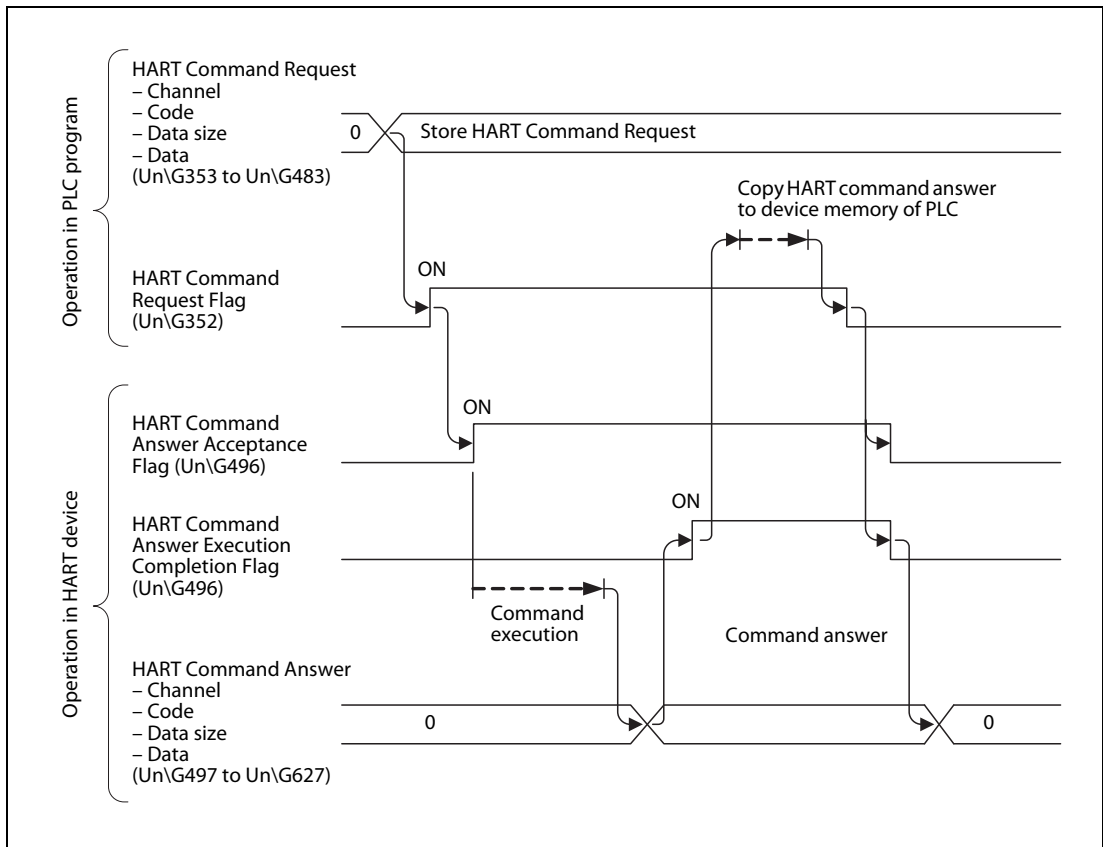

Fig. 3-40: HART command execution chart

HART Command Request Channel (Un\G353)

- Un\G353 contains the channel number (1 to 8) to which the subsequent HART Command shall be sent.

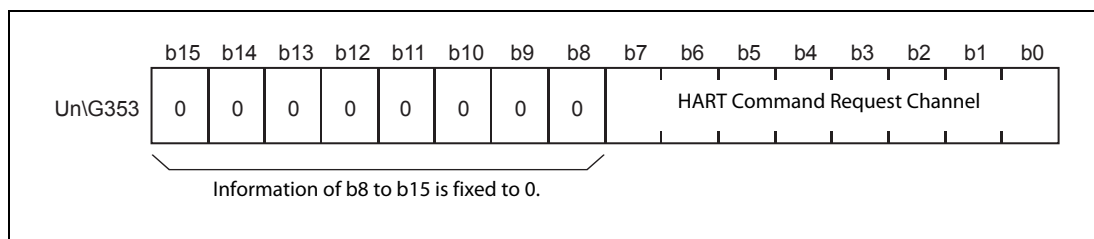

Fig. 3-41: The contents of the high byte of Un\G353 is fixed to "0"

- The relation between the setting value for the HART Command Request Channel and the channel No. is as follows:

Setting value	Command Request Target Channel
1	Channel 1
2	Channel 2
3	Channel 3
4	Channel 4
5	Channel 5
6	Channel 6
7	Channel 7
8	Channel 8

Tab. 3-33: Channel selection

HART Command Request Code (Un\G354)

- Stores the HART command according to HART specification or the instruction manual of the HART transmitter.

HART Command Request Data Size (Un\G355)

- Stores the amount of valid data to be sent in the HART Data Buffer (Un\G356 to Un\G483).
- The maximum setting value is 255.

HART Command Request Data (Un\G356 to Un\G483)

- Data to be sent to a HART device is stored in these 128 buffer memory addresses.
- The amount of data is determined by the Data Size (Un\G355). Surplus data is ignored.

3.5.31 HART Command Answer (Un\G496 to Un\G627)

HART Command Answer Flag (Un\G496)

- The high byte (b8 to b15) of Un\G496 forms the HART Command Acceptance Flag. As a reaction of a HART Command Request (refer to section 3.5.30), the HART device writes one of the following two values into this byte:

"0": Command not accepted or no request

"1": Command accepted

- The low byte (b0 to b7) contains the HART Command Execution Complete Flag. This byte has also only two states and is written by the HART device:

"0": Command not complete or no request

"1": Command complete.

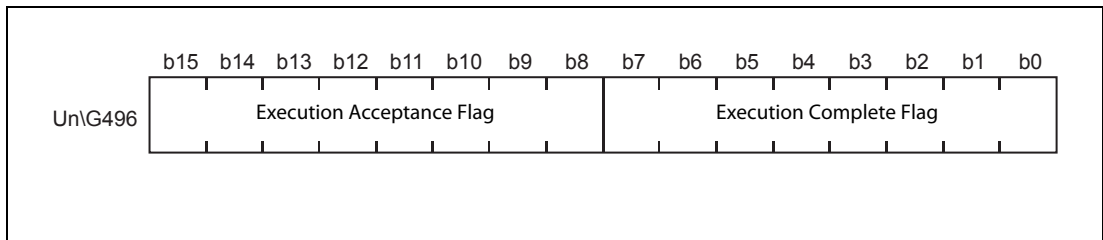

Fig. 3-42: Un\G496 is shared by the Execution Acceptance Flag and the Execution Complete Flag

HART Command Answer Channel (Un\G497)

- The channel number which has received the subsequent HART Command Answer is stored in the low byte of Un\G497.
- Range for the channel number: 1 to 8

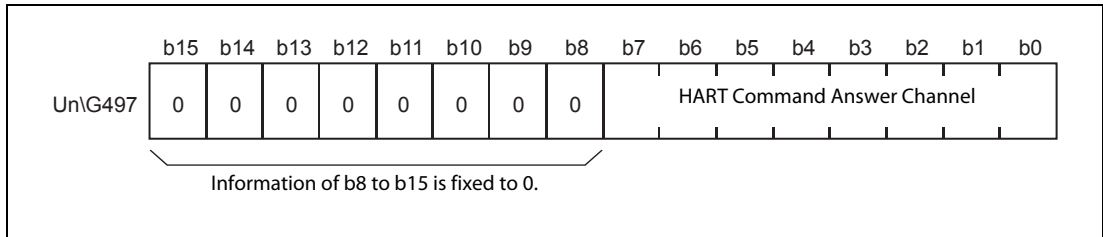

Fig. 3-43: The low byte of Un\G497 indicates the channel No.

HART Command Answer Code (Un\G498)

- Stores the HART command from the device's answer

HART Command Answer Data Size (Un\G499)

- Stores the amount of valid data in the HART Command Answer Data Buffer (Un\G500 to Un\G627).

HART Command Answer Data (Un\G500 to Un\G627)

- The received data from the device according to HART specification is stored in these 128 buffer memory addresses.
- The first two bytes are the device's status.

3.5.32 Information about HART device (Un\G896 to Un\G966, Un\G968 to Un\G1038...)

Detailed information about the connected HART devices is stored in the following areas of the buffer memory:

HART device connected to channel	Information storage area
1	Un\896 to Un\966
2	Un\968 to Un\1038
3	Un\1040 to Un\1110
4	Un\1112 to Un\1182
5	Un\1184 to Un\1254
6	Un\1256 to Un\1326
7	Un\1328 to Un\1398
8	Un\1400 to Un\1470

Tab. 3-34: Assignment of buffer memory areas

The refresh interval for the HART device information can be set in buffer memory address Un\191 (refer to section 3.5.25).

HART Tag

- The user defined HART Tag is read by HART Command #13.
- The Tag occupies four successive buffer memory addresses.
- 8 characters in ASCII format are stored, the first character in the low byte (LSB) of the lowest address.
- End of string is filled with space characters (20H).

HART Message

- The HART Message is read by HART Command #12.
- The Message occupies 16 successive buffer memory addresses.
- 32 characters in ASCII format are stored, beginning with the first character in the low byte (LSB) of the lowest address.
- End of string is filled with space characters (20H).

HART Descriptor

- The user defined HART Descriptor is read by HART Command #13.
- The Descriptor occupies 8 successive buffer memory addresses.
- 16 characters in ASCII format are stored, starting with the first character in the low byte (LSB) of the lowest address.
- End of string is filled with space characters (20H).

HART Manufacturer ID

- This indicates the manufacturer of the HART device. The name is given as a code established by the HART Communication Foundation and set by manufacturer.
- The Manufacturer ID is read by HART Command #0
- The amount of data depends on the HART Field Communications Protocol used:
 - HART 5/6: 1 byte
 - HART 7: 2 bytes

Hart Device Type

- The Hart Device Type is set by the manufacturer and read by HART Command #0.
- The amount of data depends on the HART Field Communications Protocol used:
 - HART 5/6: 1 byte
 - HART 7: 2 bytes

HART Device ID

- The HART Device ID is read by HART Command #0.
- Two successive buffer memory addresses are reserved for the Device ID.
- The Device ID occupies 3 bytes.

HART Revisions

- The HART Revisions are set by the manufacturer and read by HART Command #0.
- The revision information occupies two successive buffer memory addresses.

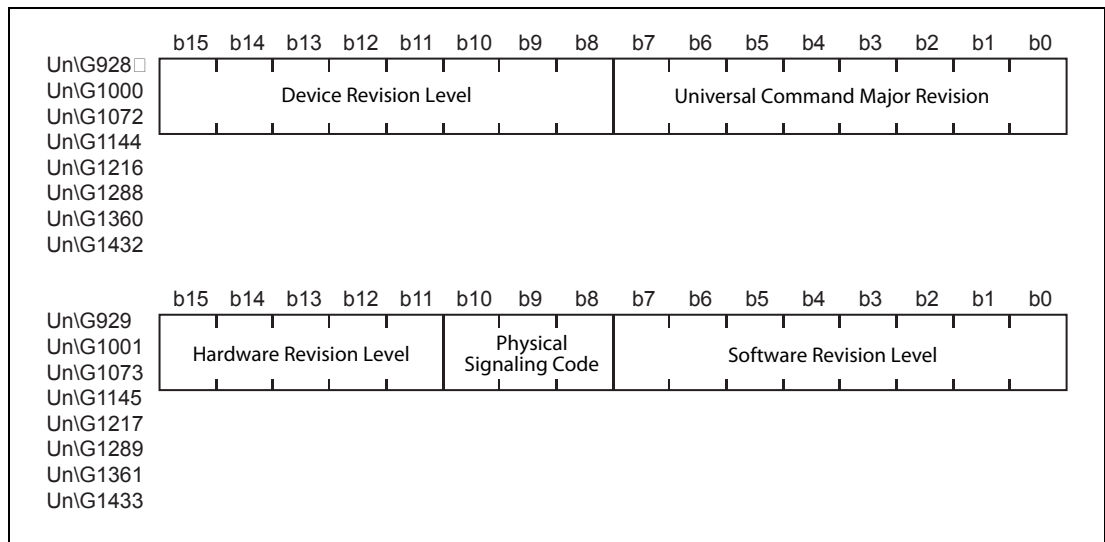

Fig. 3-44: Various revision information is stored

HART Device Function Flags

- The HART Device Function Flags are read by HART Command #0.

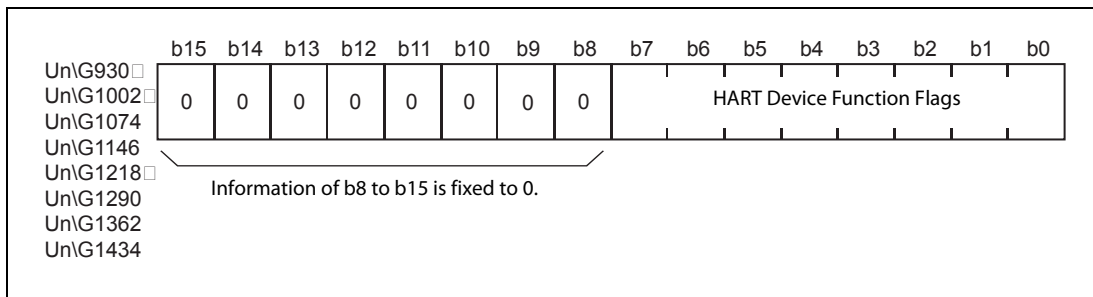

Fig. 3-45: The flags are stored in the low byte of the corresponding buffer memory address

The meaning of the bits b0 to b7 is as follows:

Bit	Meaning (when bit is set to "1")
b0	Multi-Sensor Field Device
b1	EEPROM Control
b2	Protocol Bridge Device
b3	IEEE 802.15.4 2.4GHz DSSS with O-QPSK Modulation
b4	—
b5	—
b6	C8psk Capable Field Device
b7	C8psk In Multi-Drop only

Tab. 3-35: HART Device Function Flags

HART Long Tag

- The Long Tag with international (ISO Latin 1) characters allows consistent implementation of the longer tag names required by many industry users.
- The HART Long Tag is read by HART Command #20.
- The Long Tag occupies 16 successive buffer memory addresses.
- 32 characters in ASCII format are stored, beginning with the first character in the low byte (LSB) of the lowest address.
- End of string is filled with space characters (20H).

HART Private Label Distributor

- This function is available with HART 7 only.
- The HART Private Label Distributor is read by HART Command #0 and consists of 2 bytes.

HART Device Profile

- This function is available with HART 7 only.
- The HART Device Profile is read by HART Command #0.
- The information is stored in 1 byte and in accordance with the HART Common Tables Specification.

HART Final Assembly Number

- The HART Final Assembly Number is read by HART Command #16.
- Two successive buffer memory addresses are reserved for the Final Assembly Number.
- The received information is stored in 3 bytes.

HART Date

- The HART Date (date of last calibration) is read by HART Command #13.
- The received data is stored in two successive buffer memory addresses.

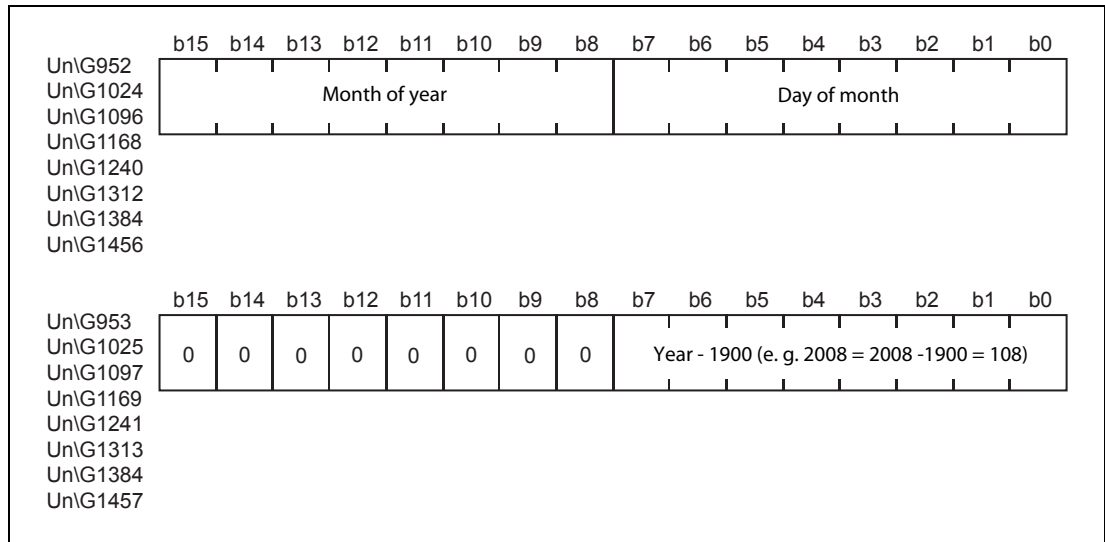

Fig. 3-46: The HART Date consists of information about day, month and year

HART Write Protect

- The HART Write Protect status is read by HART Command #15.
- One of the following three values is stored:
 - Not write protected
 - Write protected
 - Write protection is not supported by the device

HART PV Range Unit Code

- The HART PV Range Unit Code is read by HART Command #15.
- The code indicates the units used for the range settings for the primary variable (PV). The code values are defined in the HART specification.

HART PV Upper and Lower Range Value

- Upper Range Value - Primary Variable Value in engineering units for 20 mA point, set by user
- Lower Range Value - Primary Variable Value in engineering units for 4 mA point, set by user
- The upper and lower range limits for the Primary Variable (PV) are read by command #15.
- For each range value two successive buffer memory addresses are reserved. The values are stored as 32-bit floating point numbers.

NOTE

For a detailed description of floating point numbers please refer to the Programming Manual for the A/Q series and the MELSEC System Q, art. no. 87431.

HART PV Damping Value

- Damping constant for the primary variable (PV) in seconds, read by HART command #15.
- The Damping Value is stored in two successive buffer memory addresses as a 32-bit floating point number.

NOTE

For a detailed description of floating point numbers please refer to the Programming Manual for the A/Q series and the MELSEC System Q, art. no. 87431.

HART Transfer Function

- The HART Transfer Function is read by HART command #15.
- The code values are defined in the HART specification.

HART Unit Code (PV, SV, TV and FV)

- The HART Unit Code for the process variables is read by HART Commands #3 or #9.
- The code indicates the units used for the respective data item. The code values are defined in the HART specification.

4 Setup and Procedures before Operation

4.1 Handling Precautions

- Do not drop the module or subject it to heavy impact.
- Do not remove the PCB of the module from its case. Doing so may cause the module to fail.
- Prevent foreign matter such as dust or wire chips from entering the module. Such foreign matter can cause a fire, failure, or malfunction.
- Before handling the module, touch a grounded metal object to discharge the static electricity from the human body.

Failure to do so may cause the module to fail or malfunction.

- Tighten the screws such as module fixing screws within the following ranges. Loose screws may cause short circuits, failures, or malfunctions.

Screw location	Tightening torque range
Module fixing screw (M3 screw, optional)	0.36 to 0.48 Nm
Terminal block screws (M3 screws)	0.42 to 0.58 Nm
Terminal block mounting screws (M3.5 screws)	0.66 to 0.89 Nm
Terminal block screws (At the underside of the module)	0.22 to 0.25 Nm

Tab. 4-1: Tightening torques

- To mount the module on the base unit, fully insert the module fixing latch into the fixing hole in the base unit and press the module using the hole as a fulcrum.

Improper installation may result in a module malfunction, or may cause the module to fall off.

4.2 Setup and Procedures before Operation

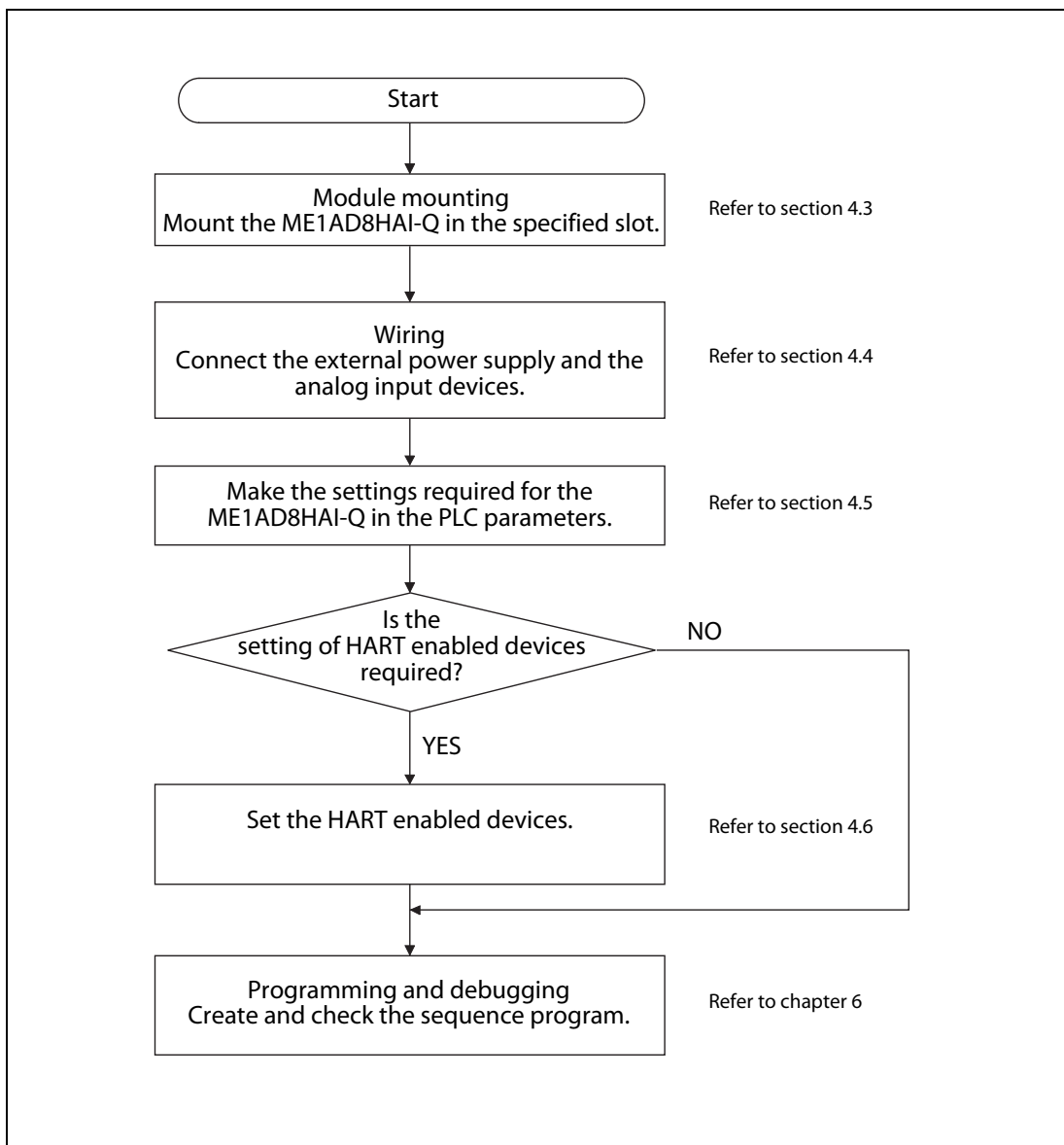

Fig. 4-1: Function chart for the setup of the HART analog input module

4.3 Installation of the Module

The ME1AD8HAI-Q can be combined with a CPU module or, when mounted to a remote I/O station, with a master module for MELSECNET/H (refer to section 2.1).

**CAUTION:**

- **Cut off all phases of the power source externally before starting the installation or wiring work.**
- **Always insert the module fixing latch of the module into the module fixing hole of the base unit. Forcing the hook into the hole will damage the module connector and module.**
- **Do not touch the conductive parts of the module directly.**

- ① After switching of the power supply, insert the module fixing latch into the module fixing hole of the base unit.
- ② Push the module in the direction of arrow to load it into the base unit.

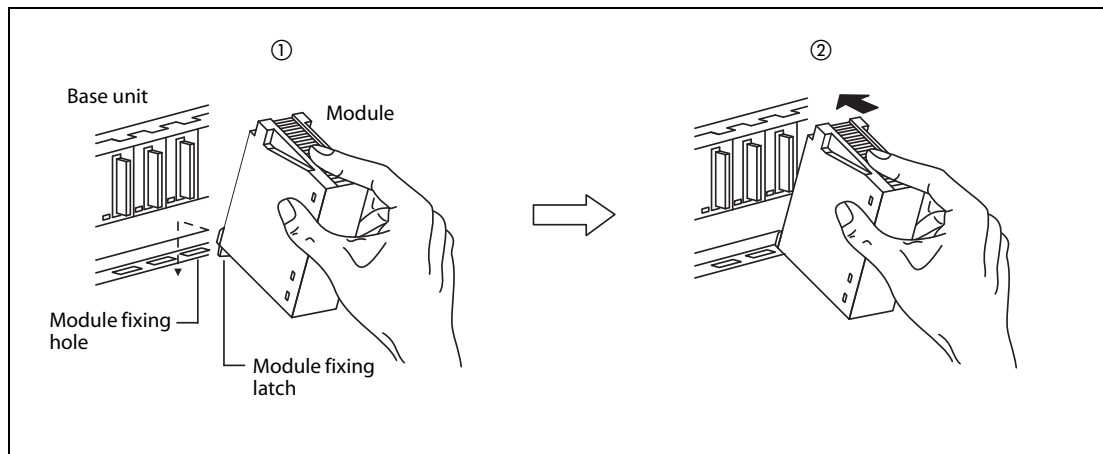

Fig. 4-2: Module installation

- ③ Secure the module with an additional screw (M3 x 12) to the base unit if large vibration is expected. This screw is not supplied with the module.

4.4 Wiring

4.4.1 Wiring precautions

In order to optimize the functions of the HART analog input module and ensure system reliability, external wiring that is protected from noise is required. Please observe the following precautions for external wiring:

- Use separate cables for the AC control circuit and the external input signals of the analog input module to prevent influences of AC surge or induction.
- Do not lay cables for analog signals close to the main circuit, high-voltage power lines, or load lines. Otherwise effects of noise or surge induction are likely to take place. Keep a safe distance of more than 100 mm from the above when wiring.
- The shield wire or the shield of the shielded cable must be grounded at one end.
- Observe the following items for wiring the terminal block. Ignorance of these items may cause electric shock, short circuit, disconnection, or damage of the product:
 - Use solderless terminals for the connection. Twist the end of stranded wires and make sure there are no loose wires.
 - Solderless terminals with insulating sleeves cannot be used for the terminal block. Covering the cable-connection portion of the solderless terminal with a marked tube or an insulation tube is recommended.
 - Do not solder-plate the electric wire ends.
 - Connect only electric wires of regular size.
 - Tightening of terminal block screws should follow the torque described on the previous page.
 - Fix the electric wires so that the terminal block and connected parts of electric wires are not directly stressed.
- When wiring to the module placed on the right side of the ME1AD8HAI-Q is difficult, remove the ME1AD8HAI-Q before wiring.
- The FG terminal of ME1AD8HAI-Q must be connected to the ground certainly.

4.4.2 External wiring

The ME1AD8HAI-Q is designed for current input only. 2-wire and 4-wire-transmitters can be connected. It is also possible to mix standard (not HART enabled) analog input devices with HART devices. For HART enabled devices, no additional wiring is required since the analog input wiring is used for communication between the ME1AD8HAI-Q and the device (section 3.3.6).

To each input channel of the ME1AD8HAI-Q one HART enabled device can be connected in a point-to-point configuration. Multidrop network connection (more than one device to one channel) is not possible.

Applicable cables

Concerning to the applicable cable, refer to the HART specification for more details.

Due to the wire resistance, capacitance and length, the external power supply voltage of the ME1AD8HAI-Q is very important for correct operation of the analog transmitter. And the external power supply voltage of the ME1AD8HAI-Q should be enough for correct operation of the analog transmitter.

Calculation of the minimum system input voltage

To ensure correct operation of the HART transmitter it is useful to calculate the minimum system input voltage.

NOTE

No matter how high the calculated voltage is, the specified external power supply voltage range of the ME1AD8HA-Q must never be exceeded from 24 V DC (+20%, -15%).

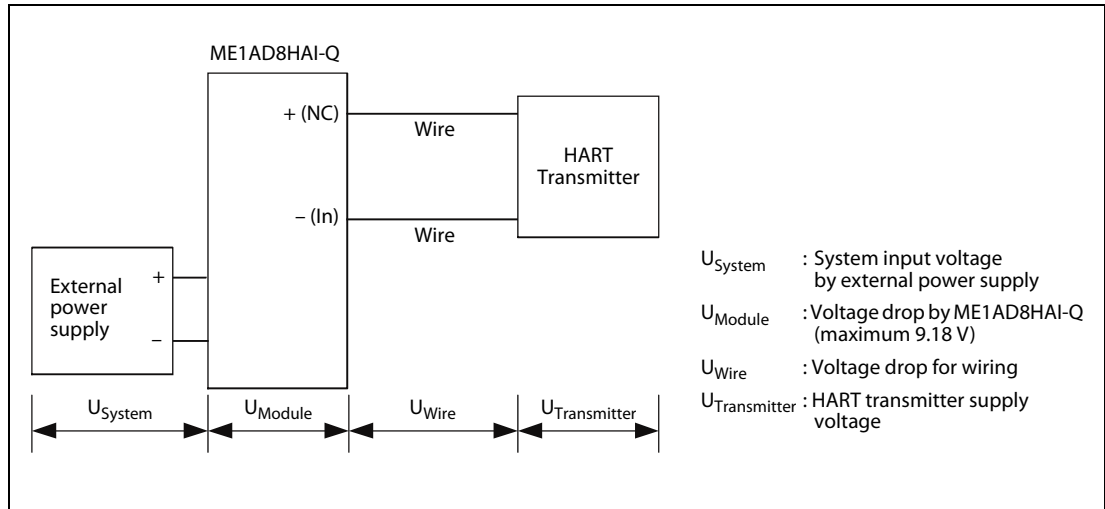

Fig. 4-3: Voltage calculation

- Step 1: Calculate the voltage drop by wiring: U_{Wire}

The voltage drop per meter for the specified cable will be determined by the cable characteristics, like in the table below.

Wire Size		Cable Resistance
Metric	AWG	
0.5 mm ²	21	36.7 Ω/km
0.75 mm ²	20	25.0 Ω/km
1.0 mm ²	18	18.5 Ω/km
1.5 mm ²	16	12.3 Ω/km

Tab. 4-2: Example of cable characteristics (from the datasheet of the specified cable)

$$U_{Wire} = \text{Total cable length} \times \text{Voltage drop per meter}$$

$$= \text{Total cable length} \times (\text{Cable resistance} \times \text{Maximum current})$$

- Step 2: Calculate the minimum system voltage by external power supply: $U_{System Min}$

$$U_{System Min} = U_{Module} + U_{Wire} + U_{Transmitter Min}$$

- $U_{System Min}$: Minimum system input voltage by external power supply
- U_{Module} : Voltage drop by ME1AD8HAI-Q
- $U_{Transmitter Min}$: Minimum HART transmitter supply voltage (refer to the HART transmitter specification)

The external power supply voltage must be more than $U_{System Min}$.

Example

Cable length between ME1AD8HAI-Q and HART transmitter (one way) = 100 m with 1mm² copper cable.

$$U_{\text{Transmitter Min}} = 12 \text{ V}$$

- Step 1: Calculate the wiring voltage drop

The cable resistance for 1mm² cable is 18.5 Ω/km.

Total cable length (two ways) = 2 x 100 m = 200 m

$$\begin{aligned} U_{\text{Wire}} &= \text{Total cable length} \times (\text{Cable resistance} \times \text{Maximum current}) \\ &= 0.2 \text{ km} \times (18.5 \text{ } \Omega/\text{km} \times 20.5 \text{ mA}) \\ &= \underline{75.85 \text{ mV}} \end{aligned}$$

- Step 2: Calculate the minimum system voltage

$$\begin{aligned} U_{\text{System Min}} &= U_{\text{Module}} + U_{\text{Wire}} + U_{\text{Transmitter Min}} \\ &= 9.18 \text{ V} + 0.07585 \text{ V} + 12 \text{ V} \\ &= \underline{21.26 \text{ V}} \end{aligned}$$

The minimum needed system voltage for this example system is 21.26 V.

This means that the external power supply voltage must be more than 21.26 V.

Cable use case:

For distances up to 800m, 0.51mm diameter with 115 nF/km cable capacitance and 36.7 Ω/km cable resistance.

2-wire transmitter input

The power for 2-wire transmitters is supplied by the ME1AD8HAI-Q.

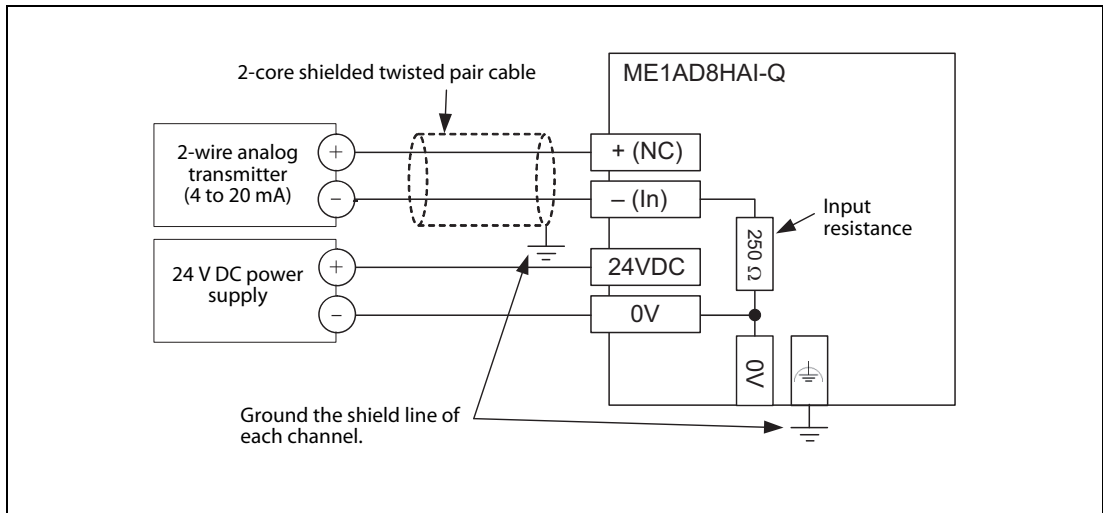

Fig. 4-4: Connection of a 2-wire transmitter

4-wire transmitter input

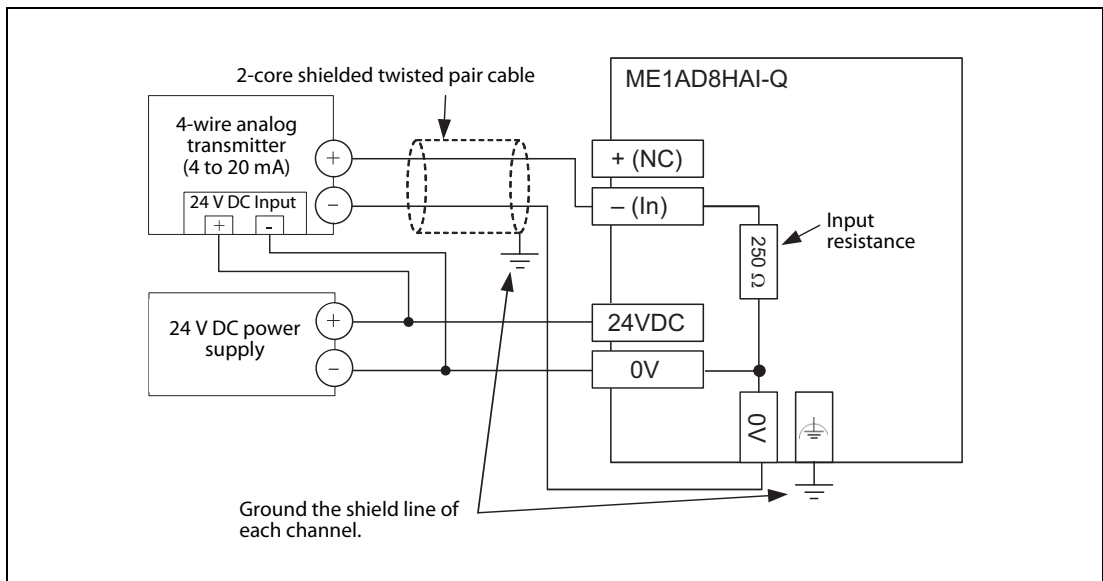

Fig. 4-5: Connection of a 4-wire transmitter

Noise filter (external power supply line filter)

A noise filter is a component which has an effect on conducted noise. It is not required to attach the noise filter to the external power supply line, however attaching it can suppress more noise.

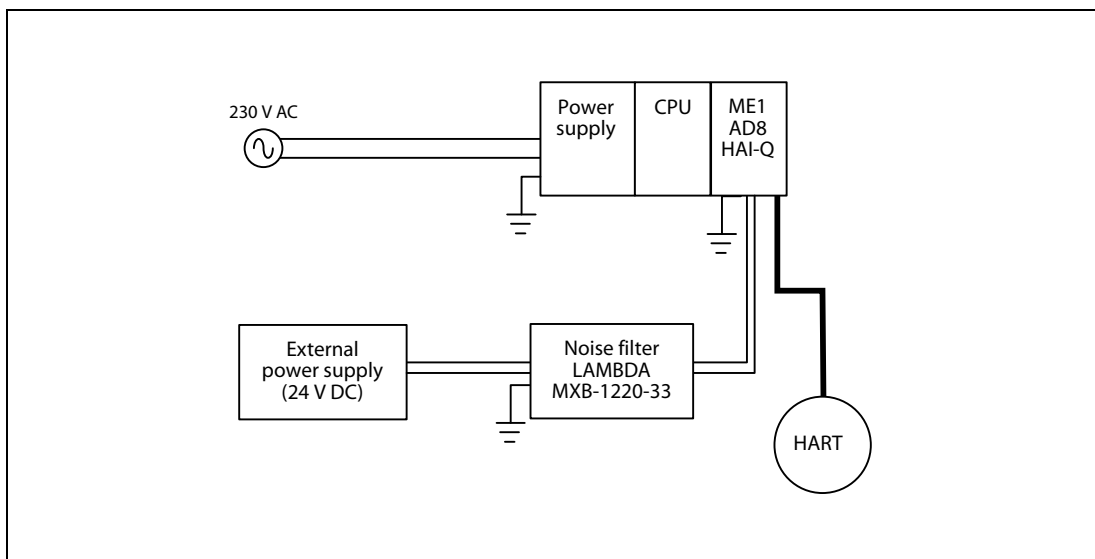

Fig. 4-6: Noise filter connection

The precautions required when installing a noise filter are described below.

- Ground the noise filter grounding terminal to the control cabinet with the shortest wire possible.
- Do not bundle the wires on the external power supply side and ME1AD8HAI-Q side of the noise filter. When bundled, the external power supply side noise will be induced into the ME1AD8HAI-Q side wires from which the noise was filtered (refer to the below figure.).

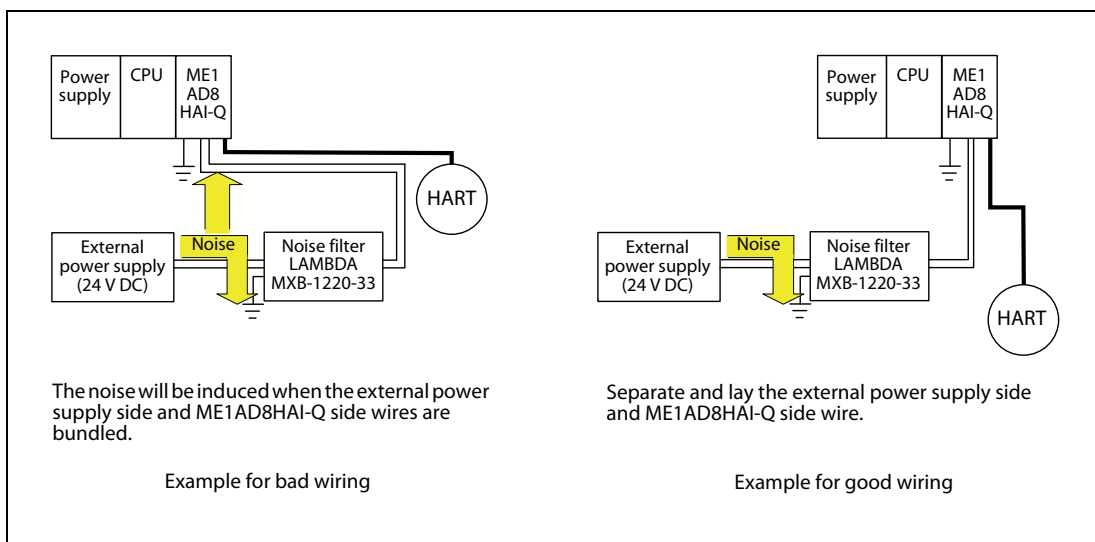

Fig. 4-7: Precautions on noise filter

The following noise filter is recommended.

Noise filter model		MXB-1220-33
Maker		LAMBDA
Rated output	Voltage	250 V AC, 250 V DC
	Current	20 A

Tab. 4-3: Recommended noise filter

4.5 PLC Parameter Setting

In the PLC parameters the I/O assignment for the ME1AD8HAI-Q and the analog input range for each channel are set.

NOTE

For setting the parameters of the ME1AD8HAI-Q, the intelligent function utility of GX Works2 can be used also (please refer to chapter 5).

4.5.1 I/O assignment

Start GX Developer or GX IEC Developer and open up the project with the ME1AD8HAI-Q. After the selection of **Parameter** in the Project Navigator Window, double-click on **PLC parameter**. The Q parameter setting window will appear. Click on the **I/O assignment** tab.

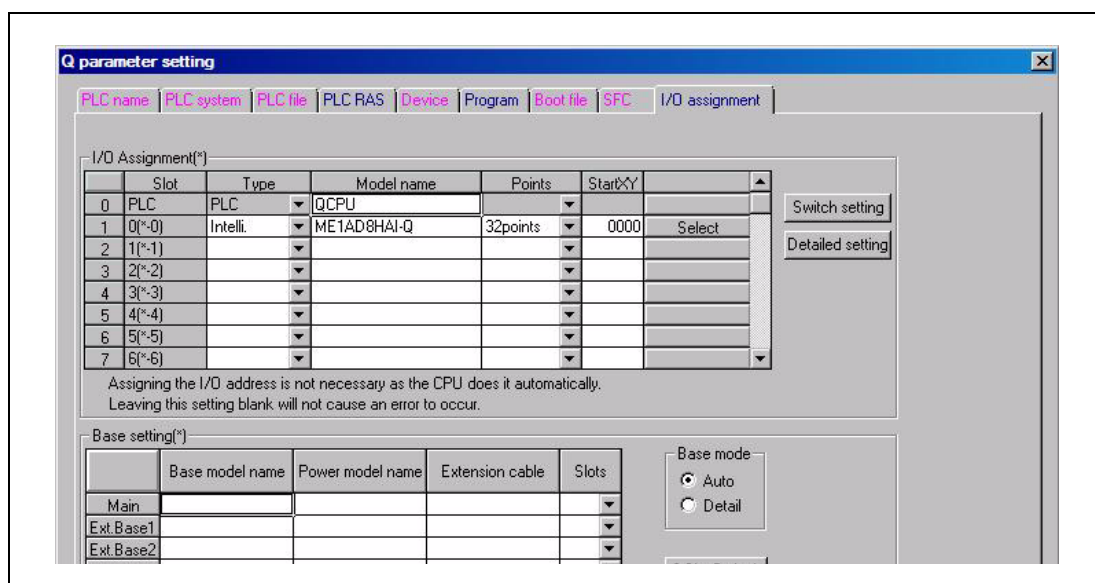

Fig. 4-8: I/O assignment setting screen

Set the following for the slot in which the ME1AD8HAI-Q is mounted:

- Type:** Select "Intelli."
- Model name:** ME1AD8HAI-Q (Entering of the module model name is optional. The entry is used for documentation only and has no effect on the function of the module.)
- Points:** Select 32 points.
- StartXY:** Start I/O number for the ME1AD8HAI-Q. (Assigning of the I/O address is not necessary as the address is automatically assigned by the PLC CPU.)

Select **Detailed settings** to specify the control PLC for the ME1AD8HAI-Q in a multiple CPU system. It is unnecessary to set the **Error time output mode** or **H/W error time PLC operation mode** since these settings are invalid for the ME1AD8HAI-Q.

4.5.2 Intelligent function module switch settings

The analog input range for each channel of the ME1AD8HAI-Q is selected by two "switches" in the PLC parameters. There are no switches at the module itself.

The intelligent function module switches are set using 16 bit data (4 hexadecimal digits).

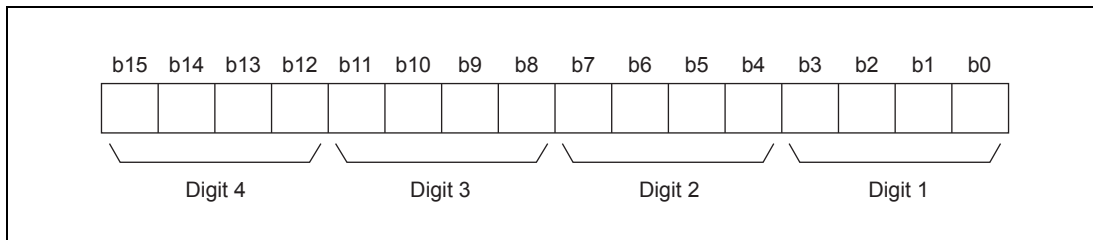

Fig. 4-9: Bit assignment for one switch

In the I/O assignment setting screen (section 4.5.1) click on **Switch setting** to display the screen shown below, then set the switches as required. The switches can easily be set if values are entered in hexadecimal. Change the entry format to hexadecimal and then enter the values.

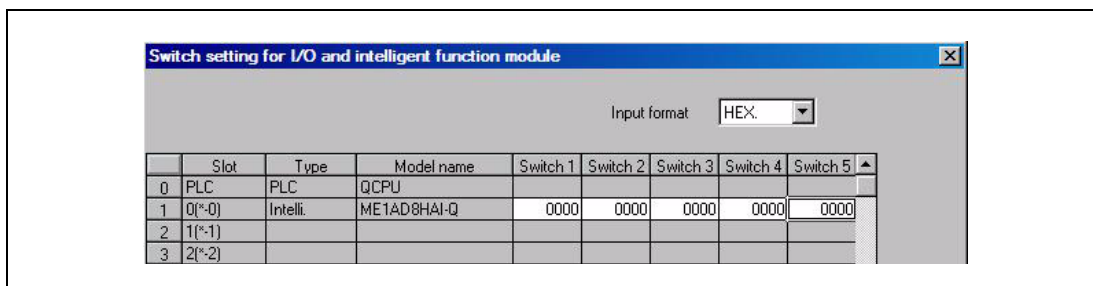

Fig. 4-10: Switch setting for intelligent function module screen

When the intelligent function module switches are not set, the default value for switches 1 to 5 is 0000H.

Switch No.	Setting item							
Switch 1	Input range setting CH1 to CH4 	<table border="1"> <thead> <tr> <th>Analog input range</th> <th>Input range setting value</th> </tr> </thead> <tbody> <tr> <td>4 to 20 mA</td> <td>0H</td> </tr> <tr> <td>0 to 20 mA</td> <td>1H</td> </tr> </tbody> </table>	Analog input range	Input range setting value	4 to 20 mA	0H	0 to 20 mA	1H
Analog input range	Input range setting value							
4 to 20 mA	0H							
0 to 20 mA	1H							
Switch 2	Input range setting CH5 to CH8 							
Switch 3	Reserved	Fixed to 0H						
Switch 4								
Switch 5								

Tab. 4-4: Switch setting item

- Setting example:
 - Analog input range CH1 and CH4: 4 to 20 mA
 - Analog input range CH2 and CH3: 0 to 20 mA
 Setting value for switch 1: 0110H

4.6 Setting of the HART Devices

For setting the parameters and monitoring the status of HART devices, MX CommDTM-HART can be used.

It supports serial CPU port connection (RS-232, USB) as well as Ethernet and MELSEC networks.

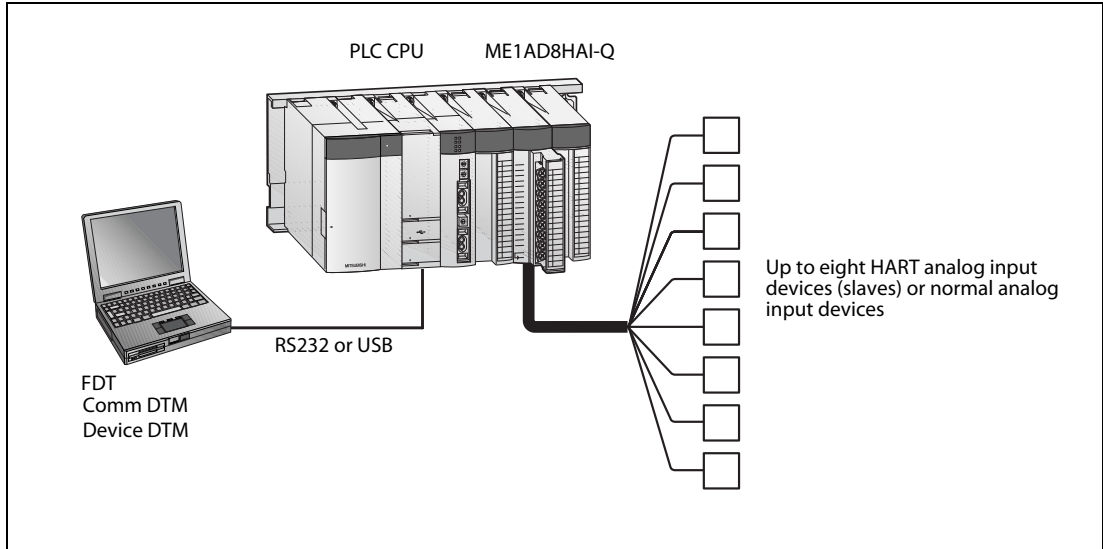

Fig. 4-11: System configuration for the connection of MX CommDTM-HART to the PLC CPU

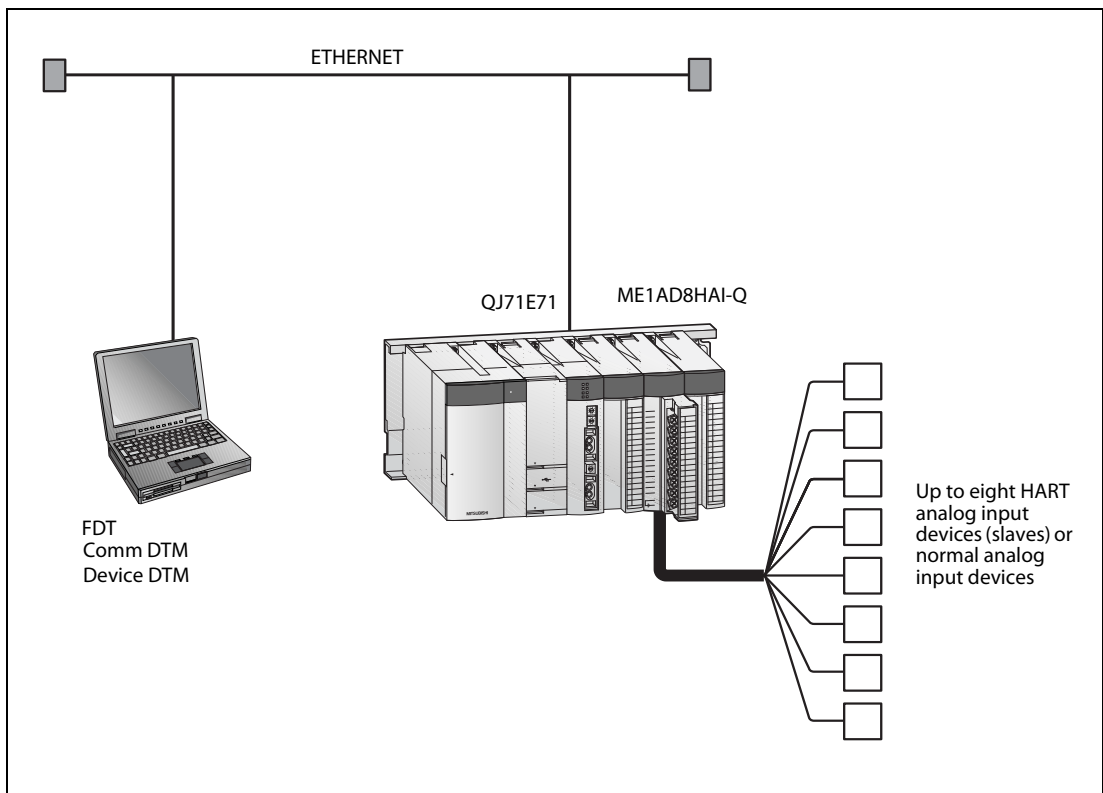

Fig. 4-12: System configuration for the Ethernet connection of MX CommDTM-HART

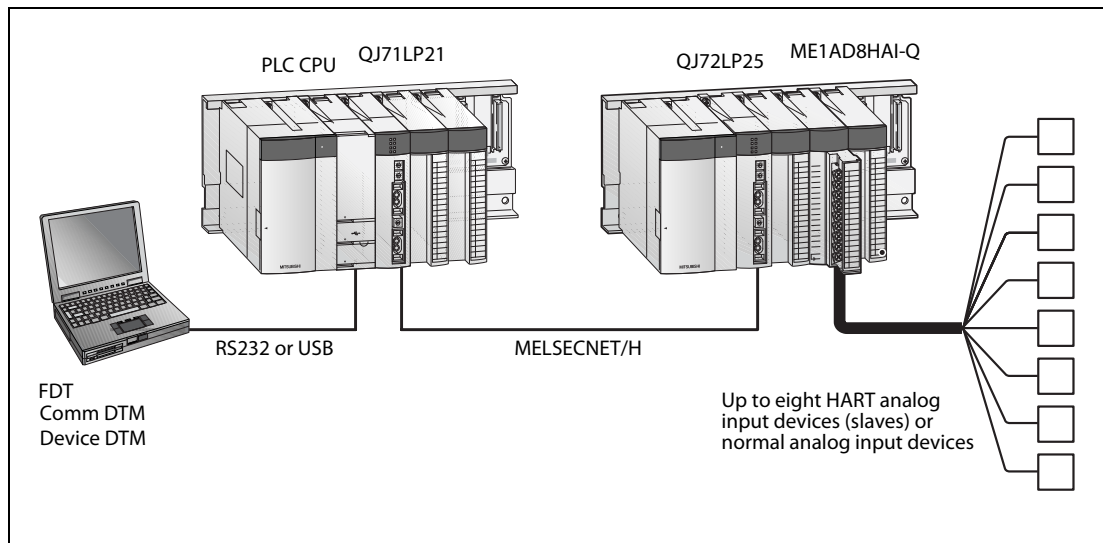

Fig. 4-13: Connection of MX CommDTM-HART via MELSECNET/H

- CommDTM for ME1AD8HAI-Q

It can be downloaded from the following web-site:

http://www.mitsubishi-automation.com/mymitsubishi_index.html

Menu "MyMitsubishi" → (Login) → "Downloads" → "Tools"

- Device DTM for each HART transmitter

Please ask the manufacturer of each HART transmitter.

5 Intelligent Function Utility (GX Works2)

The programming software GX Works2 allows the quick and easy parameter setting for intelligent function modules like the ME1AD8HAI-Q.

Programming is reduced because the initial setting and automatic data exchange between PLC CPU and ME1AD8HAI-Q can be configured on the screen. In addition, the "switches" of intelligent function modules can be set easily.

5.1 Addition of a new Module to the Project

To add a new intelligent function module to a project, click on **Intelligent Function Module** in the Project Navigation window. After a right click, select **New Module**.

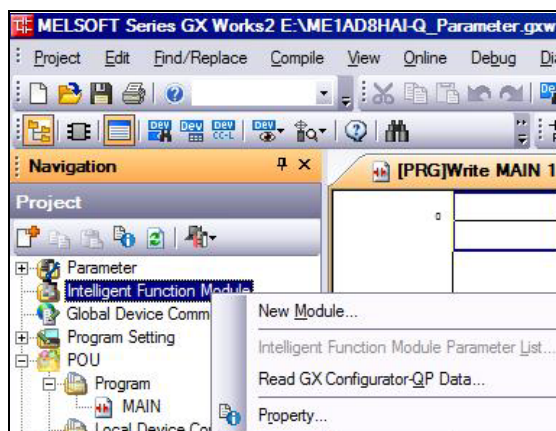

Fig. 5-1: Addition of a new intelligent function module

The window **New Module** is displayed.

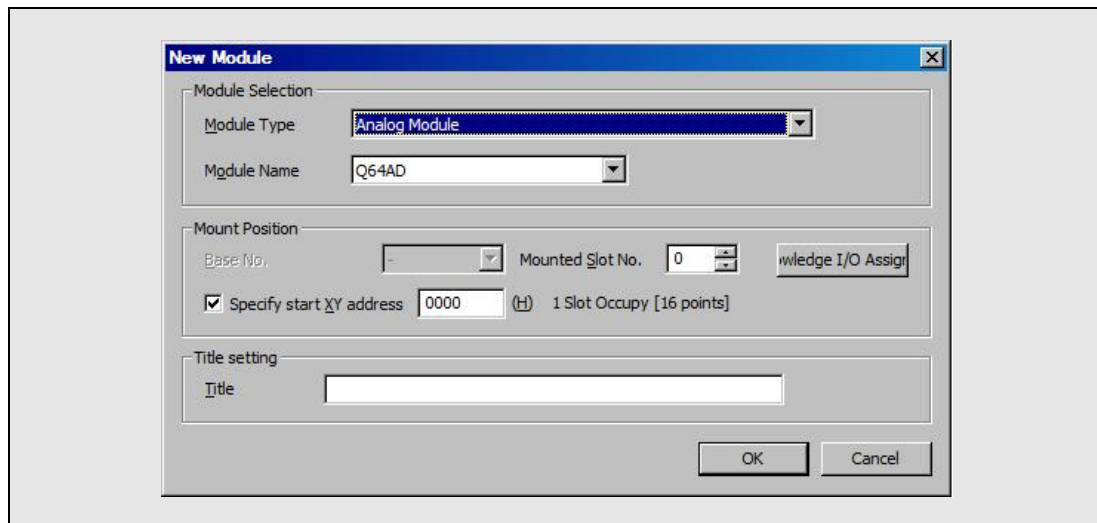

Fig. 5-2: Selection of an intelligent function module

Select **HART Analog Module**.

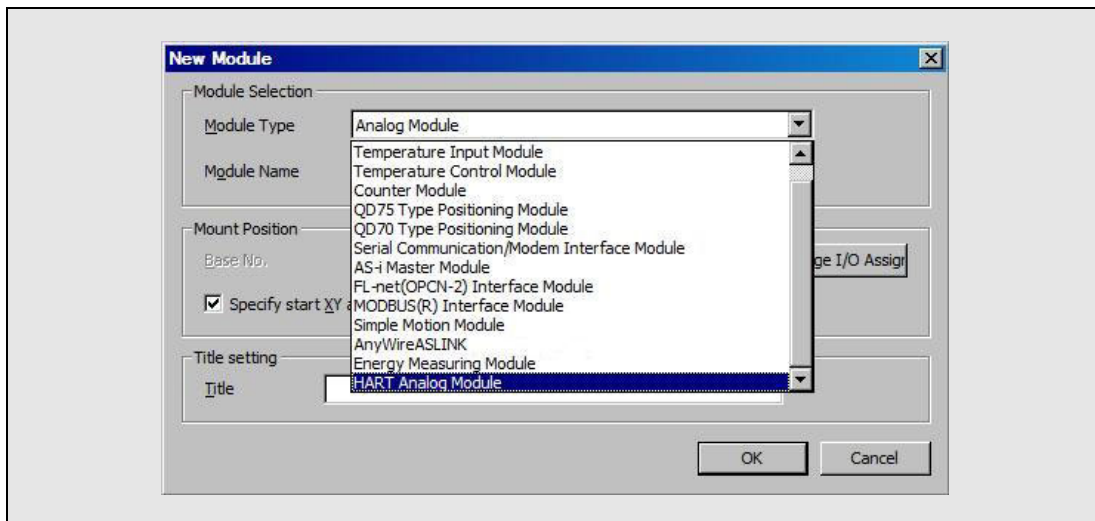

Fig. 5-3: Selection of the HART modules

Afterwards, select **ME1AD8HAI-Q**.

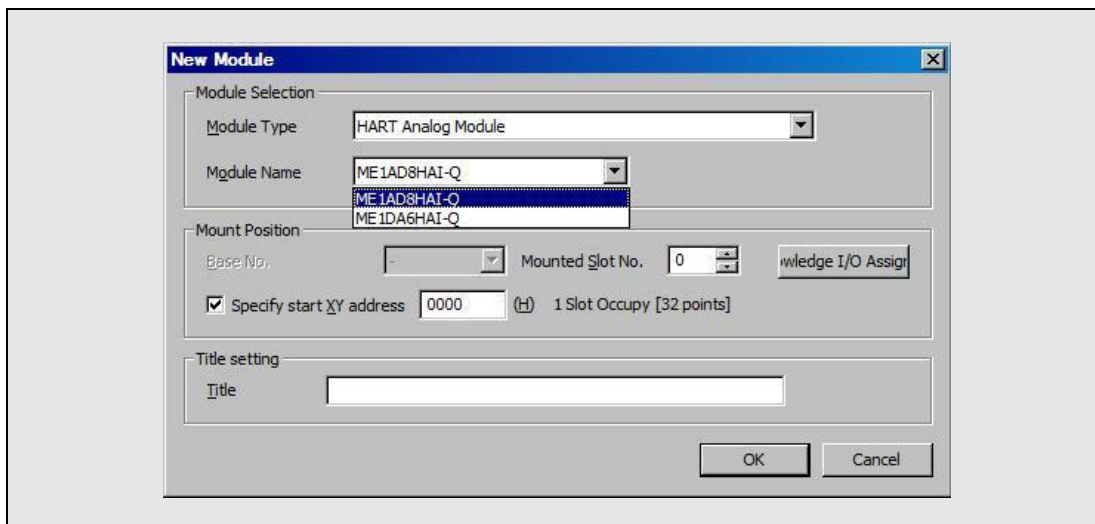

Fig. 5-4: Selection of the ME1AD8HAI-Q

Enter the slot No. where the module is mounted (**Mounted Slot No.**) and the start I/O number. As **Title** you can, for instance, enter an individual name for the module. This name is then displayed in the Project Navigation window.

Afterwards click on **OK**.

The settings are reflected in the PLC parameters automatically. An I/O assignment (section 4.5.1) there is no longer required.

No.	Slot	Type	Model Name	Points	Start XY	Switch Setting
0	PLC	PLC				
1	0(*-0)	Intelligent	ME1AD8HAI-Q	32Points	0000	Detailed Setting
2	1(*-1)					

Fig. 5-5: Display of the I/O assignment in the PLC parameters

5.2 Switch Setting

The "switches" of intelligent function modules, otherwise set in the PLC parameters (refer to section 4.5.2), can be set very clearly with GX Works2.

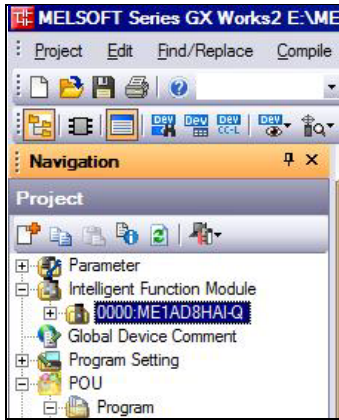

Fig. 5-6:
In the Project Navigation window, click on the plus sign in front of the module name in order to show the setting options.

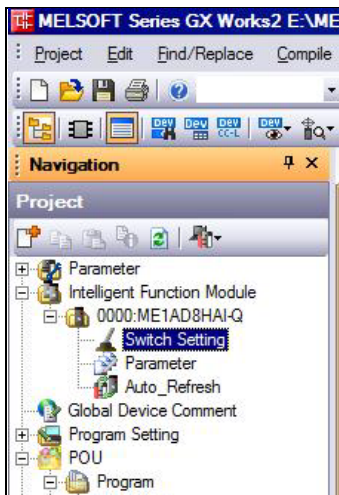

Fig. 5-7:
Double-click on **Switch Setting**.

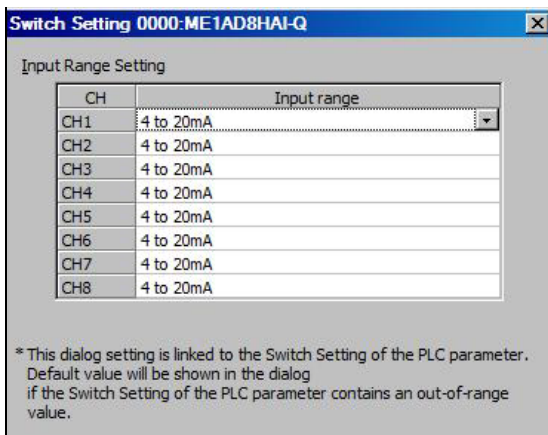

Fig. 5-8:
In this dialog box the input range of each channel can be set.

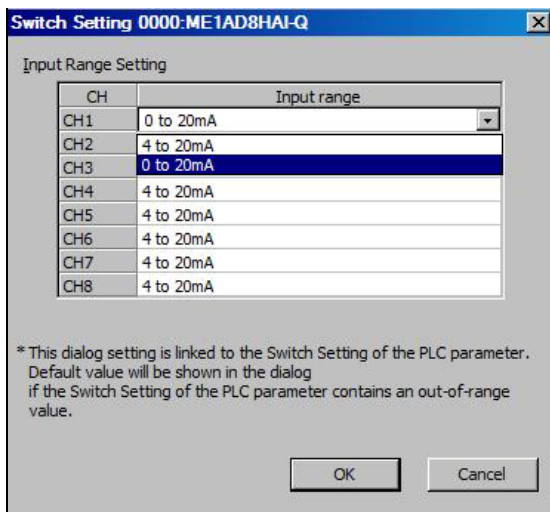

Fig. 5-9: Select the desired input range from the list and click on **OK** afterwards.

The settings are reflected in the PLC parameters automatically. Therefore switch setting is no longer required there.

	Slot	Type	Model Name	Switch1	Switch2	Switch3	Switch4	Switch5
0	PLC	PLC						
1	0(*-0)	Intelligent	ME1AD8HAI-Q	0001	0000	0000	0000	0000
2	1(*-1)							

Fig. 5-10: Display of the switch settings in the PLC parameters

5.3 Parameter Setting

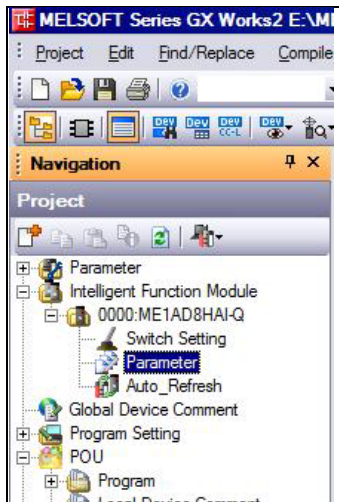

Fig. 5-11: Double-click on **Parameter**.

Item	CH1	CH2	CH3	CH4	CH5	CH6	CH7	CH8
Basic setting								
A/D conversion enable/disable setting	0:Enable	0:Enable	0:Enable	0:Enable	0:Enable	0:Enable	0:Enable	0:Enable
Averaging process setting								
Average time/Average number of times/Moving average/Time constant settings	0:Sampling	0:Sampling	0:Sampling	0:Sampling	0:Sampling	0:Sampling	0:Sampling	0:Sampling
	0:Sampling 1:Time Average 2:Count Average 3:Moving Average 4:Primary Delay Filter		0	0	0	0	0	0
Warning output function								
Process alarm warning output settings	1:Disable	1:Disable	1:Disable	1:Disable	1:Disable	1:Disable	1:Disable	1:Disable
Process alarm upper upper limit value	0	0	0	0	0	0	0	0
Process alarm upper lower limit value	0	0	0	0	0	0	0	0
Process alarm lower upper limit value	0	0	0	0	0	0	0	0
Process alarm lower lower limit value	0	0	0	0	0	0	0	0
Rate alarm warning output settings	1:Disable	1:Disable	1:Disable	1:Disable	1:Disable	1:Disable	1:Disable	1:Disable
Rate alarm warning detection period	0 ms	0 ms	0 ms	0 ms	0 ms	0 ms	0 ms	0 ms
Rate alarm upper limit value	0.0 %/s	0.0 %/s	0.0 %/s	0.0 %/s	0.0 %/s	0.0 %/s	0.0 %/s	0.0 %/s
Rate alarm lower limit value	0.0 %/s	0.0 %/s	0.0 %/s	0.0 %/s	0.0 %/s	0.0 %/s	0.0 %/s	0.0 %/s
Input signal error detection								
Input signal error detection setting	1:Disable	1:Disable	1:Disable	1:Disable	1:Disable	1:Disable	1:Disable	1:Disable
Input signal error detection setting value	5.0 %	5.0 %	5.0 %	5.0 %	5.0 %	5.0 %	5.0 %	5.0 %
Scaling function								
Set about the scaling of A/D conversion.								
Scaling enable/disable setting	1:Disable	1:Disable	1:Disable	1:Disable	1:Disable	1:Disable	1:Disable	1:Disable
Scaling upper limit value	0	0	0	0	0	0	0	0
Scaling lower limit value	0	0	0	0	0	0	0	0
HART function								
Set about HART communication.								
HART enable/disable setting	0:Disable	0:Disable	0:Disable	0:Disable	0:Disable	0:Disable	0:Disable	0:Disable
HART maximum retries	3	3	3	3	3	3	3	3
HART device information refresh interval	30 s							

Fig. 5-12: Dialog box for parameter setting

Double-click an item to change the setting. Depending on the type of item this action displays a pull-down list with options to choose from or a setting value can be entered directly.

The individual settings are shown on the next page.

Item		Reference (section)
Basic setting	A/D conversion enable/disable setting	3.5.2
	Averaging process setting	3.5.8
	Average time/Average number of times/Moving average/Time constant settings	3.5.3
Warning output function	Process alarm warning output settings	3.5.11
	Process alarm upper upper limit value	3.5.17
	Process alarm upper lower limit value	
	Process alarm lower upper limit value	
	Process alarm lower lower limit value	
	Rate alarm warning output settings	3.5.11
	Rate alarm warning detection period	3.5.18
	Rate alarm upper limit value	3.5.19
Rate alarm lower limit value		
Input signal error detection	Input signal error detection setting	3.5.10
	Input signal error detection setting value	3.5.20
Scaling function	Scaling enable/disable setting	3.5.14
	Scaling upper limit value	3.5.16
	Scaling lower limit value	
HART function	HART enable/disable setting	3.5.21
	HART maximum retries	3.5.24
	HART device information refresh interval	3.5.25

Tab. 5-1: Adjustable parameter of the ME1AD8HAI-Q

5.4 Auto Refresh Settings

Data in the buffer memory of an intelligent function module can be transferred to the device memory of the PLC CPU automatically. By using the auto refresh function, the transfer of this data by the sequence program is unnecessary.

The buffer memory that was set for automatic refresh is automatically read and written to the specified device when the END command for the programmable controller CPU is executed.

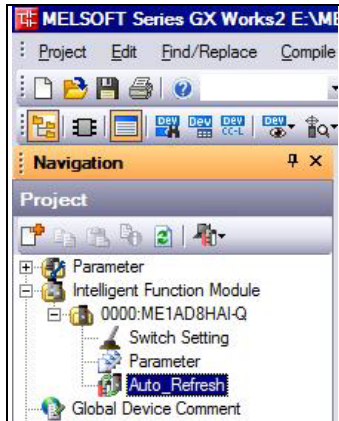

Fig. 5-13:
Double-click on **Auto_Refresh**

Item	CH1	CH2	CH3	CH4	CH5	CH6	CH7	CH8
Common	Common							
Transfer to CPU	The data of the buffer memory is transmitted to the specified device.							
Digital output value	D1	D2	D3	D4	D5	D6	D7	D8
Maximum value								
Minimum value								
Scaling value								
Warning output flag (Process alarm)	M0							
Warning output flag (Rate alarm)	M16							
Input signal error detection flag	M32							
Error code	D10							
HART function	HART function							
Transfer to CPU	The data of the buffer memory is transmitted to the specified device.							
HART scan list	M48							
Current HART cycle time								
Maximum HART cycle time								
Minimum HART cycle time								
Status of the slave device	Status of the slave device							
HART field device status								
HART extended device status								
Device variable status: Primary and Secondary Value (PV and SV)								
Device variable status: Tertiary and Fourth Value (TV and FV)								
HART process variable: Primary value (32 bit)								
HART process variable: Secondary value (32 bit)								
HART process variable: Tertiary value (32 bit)								
HART process variable: Fourth value (32 bit)								

Fig. 5-14: Example for the automatic refresh of PLC devices

NOTES

Available devices for auto refresh are: X, Y, M, L, B, T, C, ST, D, W, R and ZR.

When a bit device is used, set the head address to "0" or to a value that is divisible by 16 points (example: X10, Y120, M16).

When storing in bit devices, the data in the buffer memory are stored in 16 points of devices from the set device No. (Example: When M16 is set, the data is stored in M16 to M31.)

5.5 Writing the Intelligent Function Module Settings to the PLC

When writing the settings for the intelligent function module to the PLC, make sure that the "Intelligent Function Module Parameter" are tagged in the **Online Data Operation** dialog box.

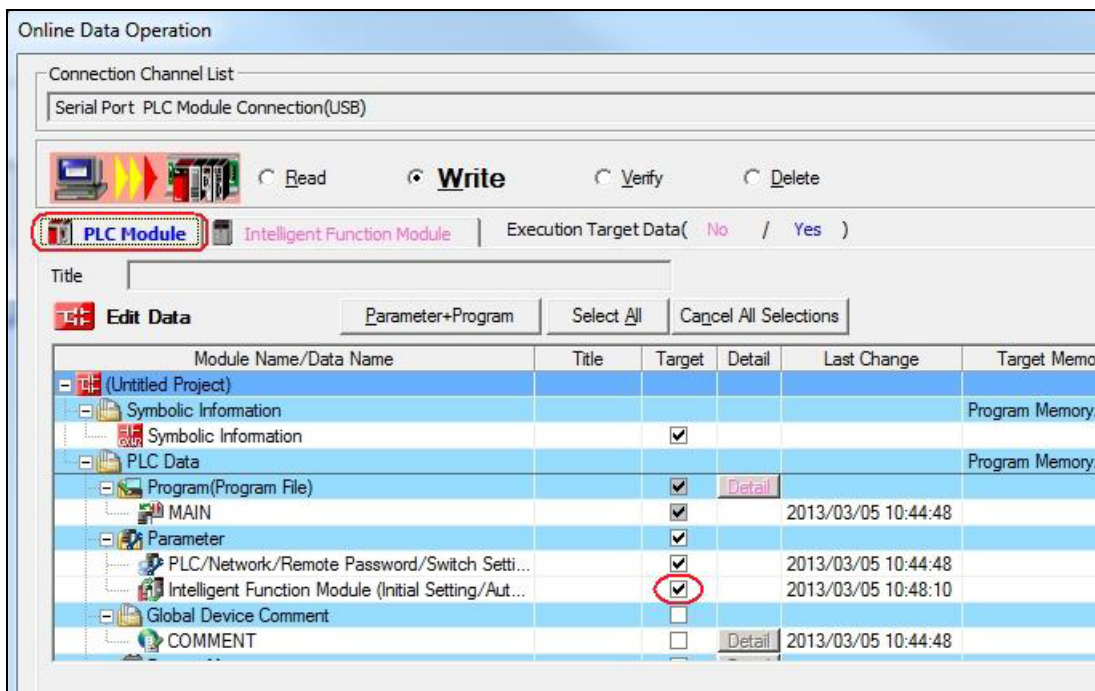

Fig. 5-15: Selection of intelligent function module parameters on the tab "PLC Module"

On the tab "Intelligent Function Module", select the ME1AD8HAI-Q.

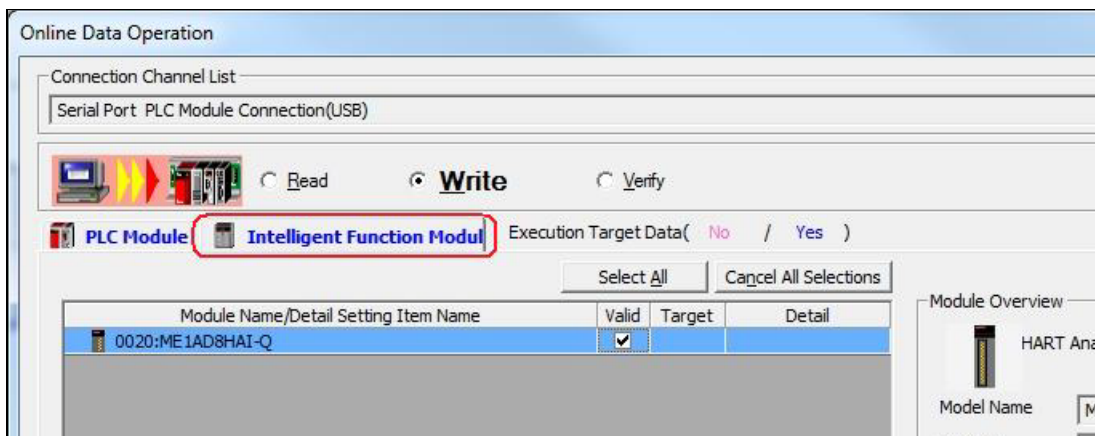

Fig. 5-16: Selection of the HART analog input module

6 Programming

This chapter describes the programs of the HART analog input module ME1AD8HAI-Q.

NOTE When applying any of the program examples introduced in this chapter to the actual system, verify the applicability and confirm that no problems will occur in the system control.

6.1 Programming Procedure

In the following procedure, create a program that will execute the analog/digital conversion of the ME1AD8HAI-Q.

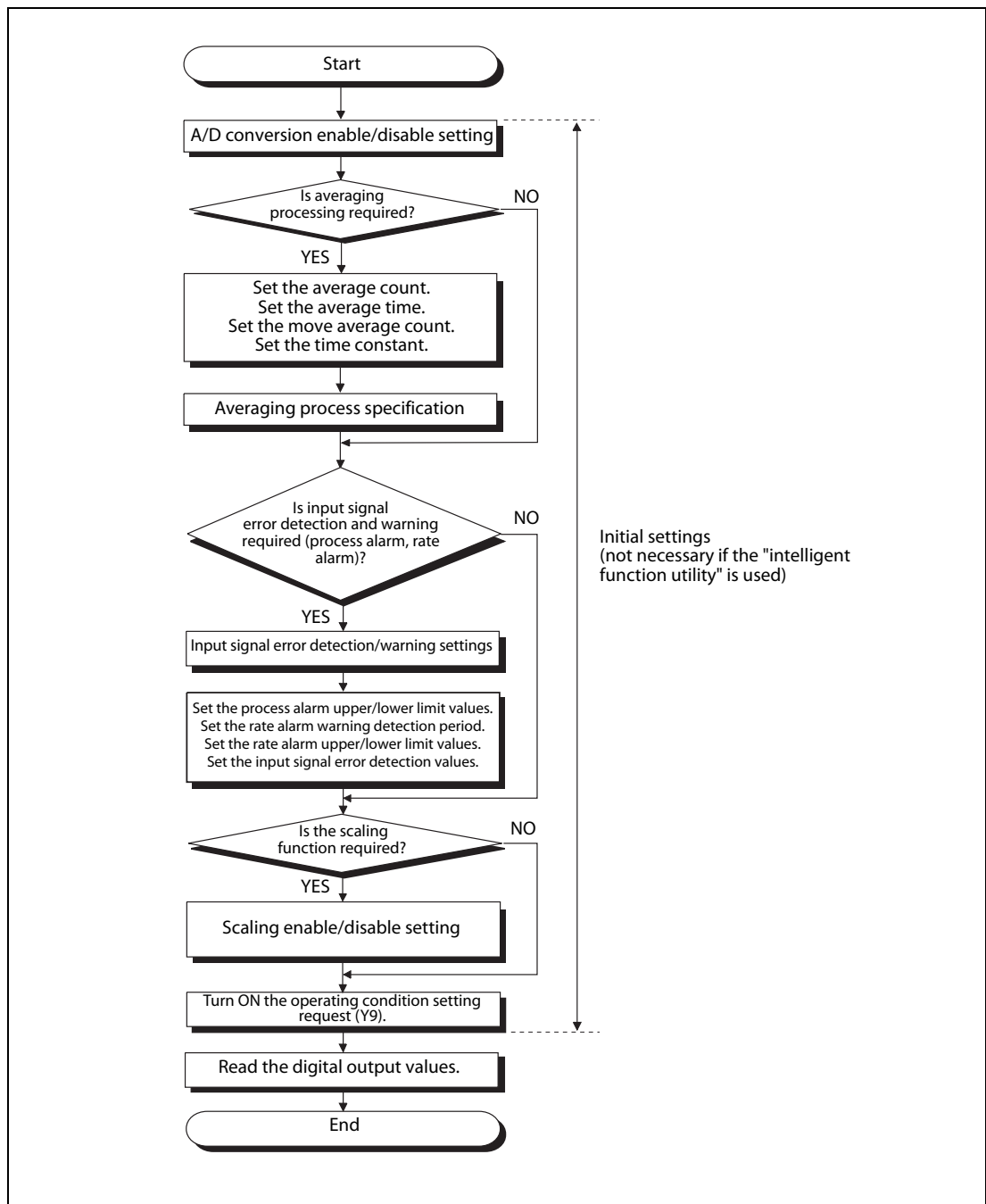

Fig. 6-1: Programming procedure for the ME1AD8HAI-Q

6.2 Example 1: ME1AD8HAI-Q combined with PLC CPU

The following figure shows the system configuration used for this example. Three HART enabled analog input devices are connected to a ME1AD8HAI-Q.

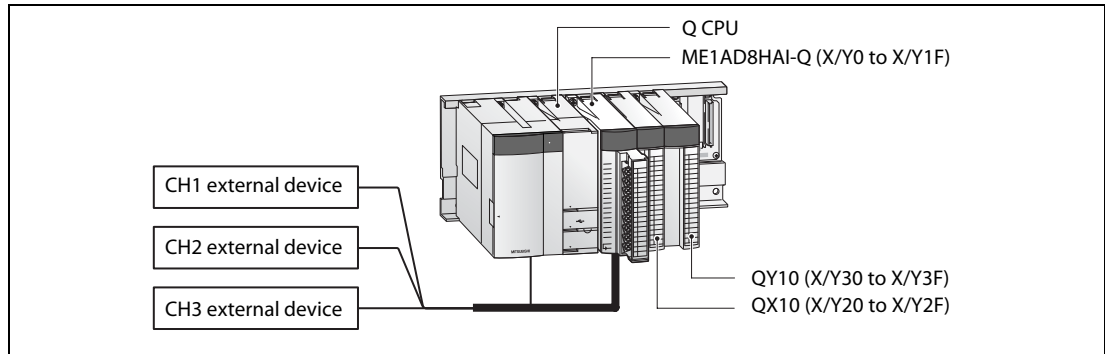

Fig. 6-2: In this example the ME1AD8HAI-Q is mounted on the main base unit together with an input and an output module.

Channel	Input range setting
CH1	4 to 20 mA
CH2	
CH3	
CH4 to CH8	not used

Tab 6-1: Conditions for the intelligent function module switch setting

Program conditions

- The following averaging processing specification is used for each channel.
 - CH1: Sampling processing
 - CH2: Time averaging (1000 ms)
 - CH3: Primary delay filtering (100 ms)
- CH1 uses the input signal error detection function (Refer to section 3.3.3.)
 - Input signal error detection: 10 %
- CH2 uses the warning output setting (process alarm) (Refer to section 3.3.4.)
 - Process alarm upper upper limit value: 7000
 - Process alarm upper lower limit value: 6000
 - Process alarm lower upper limit value: 1500
 - Process alarm lower lower limit value: 1000
- CH3 uses the warning output setting (rate alarm) (Refer to section 3.3.4)
 - Rate alarm warning detection period : 800 ms
 - Rate alarm upper limit value: 0.3 %
 - Rate alarm upper limit value: 0.1 %
- In the event of a write error, an error code shall be displayed in BCD format. The error code shall be reset after removal of the cause.
- A warning lamp for each channel is switched ON if the connected device is malfunctioning.

6.2.1 Before creating a program

Perform the following steps before creating a program.

Wiring of external devices

Mount the ME1AD8HAI-Q on the base unit and connect the external power supply and the external devices. For details, refer to section 4.4.

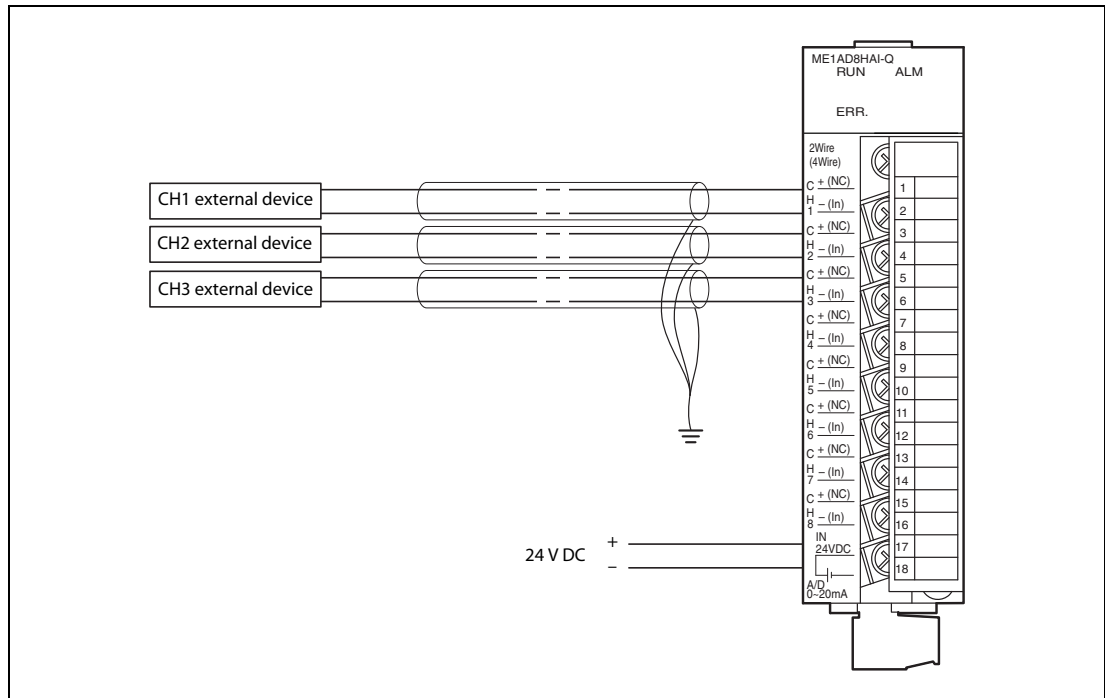

Fig. 6-3: External wiring required for this example

Intelligent function module switch setting

Based on the setting conditions given on the previous page, make the intelligent function module switch settings. Since the analog input range is 4 to 20 mA for default, no setting is necessary when a brand-new module is used. For an module used before in an other application, checking and setting of the switches is required.

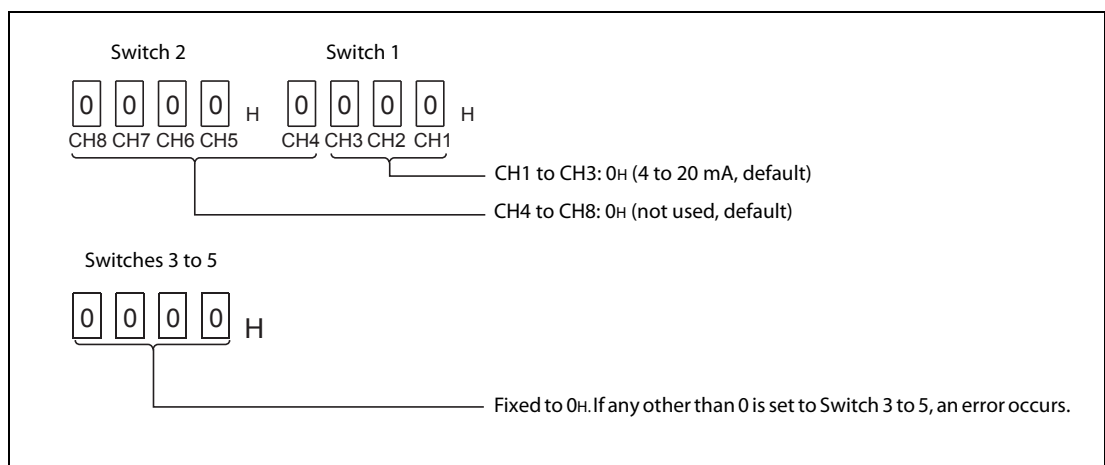

Fig. 6-4: Setting of the switches 1 to 5

On GX Developer's or GX IEC Developer's **Parameter setting** screen, select the **I/O assignment** tab, click **Switch setting**, and make settings of Switch 1 to 5 as on the screen shown below (for details about the setting, refer to section 4.5.2).

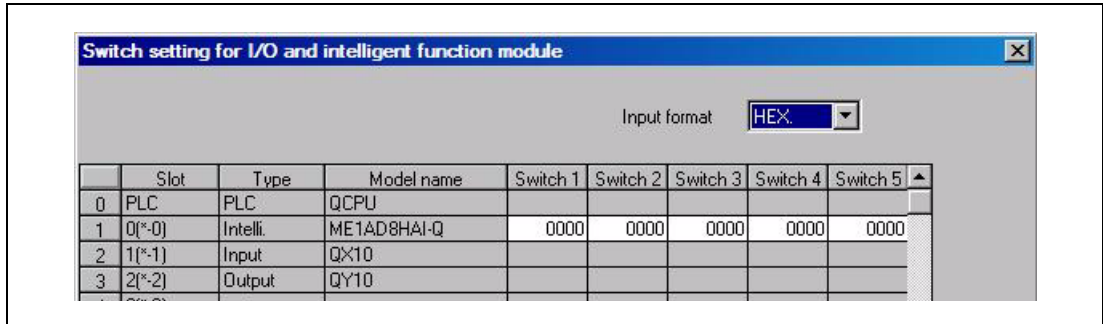

Fig. 6-5: Switch setting for this example

6.2.2 Program

Device	Function	Remark		
Inputs	X0	Module ready		
	X9	Operating condition setting completed flag		
	XC	Input signal error detection signal	ME1AD8HAI-Q (X0 to X1F)	
	XE	A/D conversion completed flag		
	XF	Error flag		
	X20	Digital output value read command input signal		
	X21	Input signal error detection reset signal		
	Inputs	X22	Error reset signal	QX10 (X20 to X2F)
		X23	CH1 HART device communication request	
		X24	CH2 HART device communication request	
X25		CH3 HART device communication request		
Outputs		Y9	Operating condition setting request	
	YF	Error clear request		
	Y30 to Y3B	Error code display (BCD 3 digits)	QY10 (Y30 to Y3F)	
	Y3C	Warning lamp: CH1 input device malfunction		
	Y3D	Warning lamp: CH2 input device malfunction		
Internal relays	Y3F	Warning lamp: CH3 input device malfunction		
	M0, M1, M2	A/D conversion completed flags CH1 to CH3	The A/D conversion completed flags of all channels are stored in M0 to M7.	
	M12, M13	CH2 Warning output flag (Process alarm)	The warning output flags for all channels are stored in M10 to M25 resp. M30 to M45.	
	M34, M35	CH3 Warning output flag (Rate alarm)		
	M50	CH1 Input signal error detection flag	The input signal error detection flags of all channels are stored in M50 to M57.	
	M100, M101, M102	HART device found at CH1 to CH3	M100 to M107 are set when a HART device is detected at the channels 1 to 8.	
	M117	CH1 device malfunction	M110 to M117: Status of HART field device connected to CH1	
Register	M127	CH2 device malfunction	M120 to M127: Status of HART field device connected to CH2	
	M137	CH3 device malfunction	M130 to M137: Status of HART field device connected to CH3	
	D1	CH1 Digital output value		
Register	D2	CH2 Digital output value		
	D3	CH3 Digital output value		

Tab 6-2: List of used devices

● Initial settings

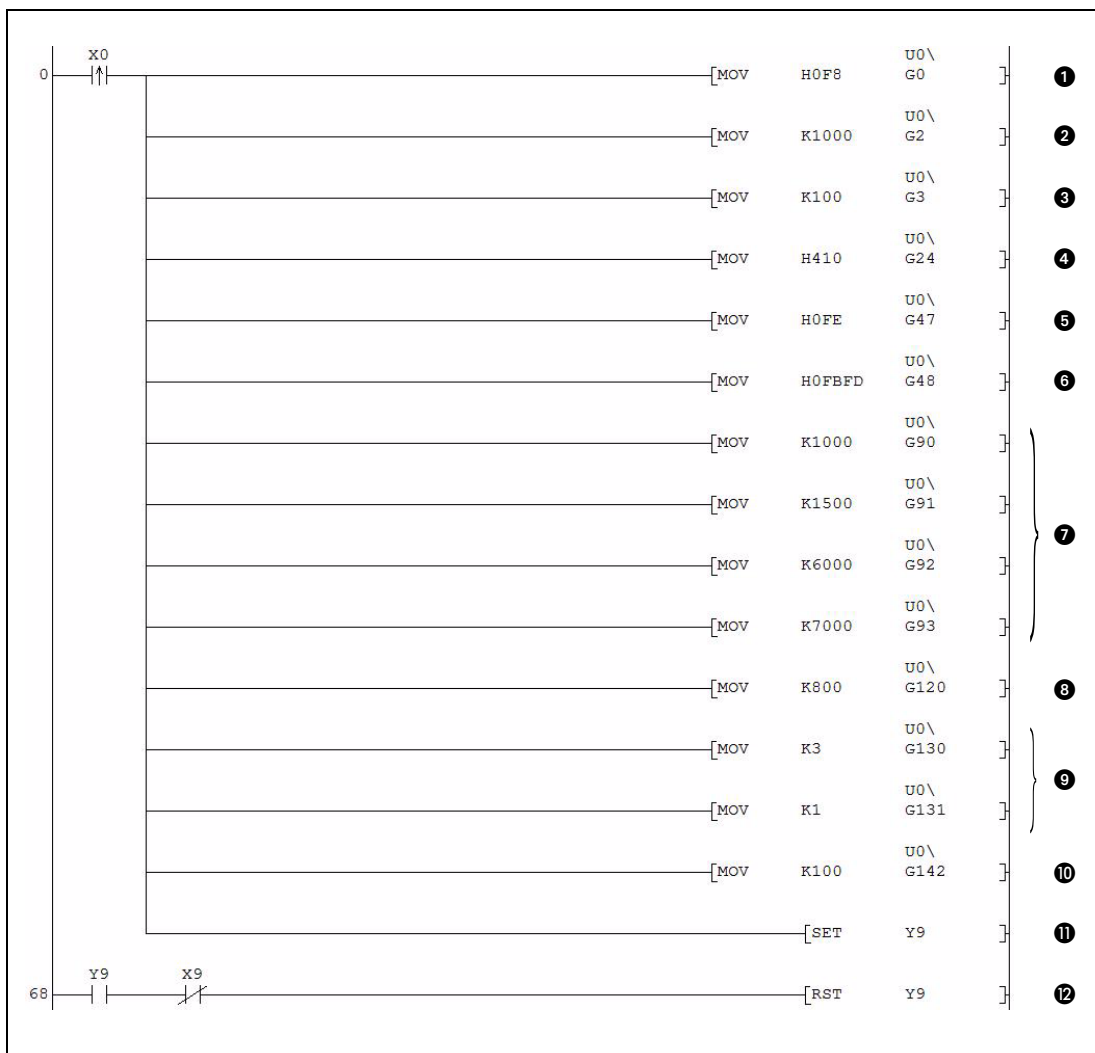

Fig. 6-6: Initial settings performed by the sequence program

Number	Description	
1	A/D conversion enable/disable setting (CH1, CH2, CH3: enable)	
2	Average time / Average number of times / Move average /	CH2: Time averaging (1000 ms)
3	Time constant settings	CH3: Primary delay filtering (100 ms)
4	Averaging process specification (CH1: Sampling processing, CH2: Time averaging, CH3: Primary delay filtering)	
5	Input signal error detection settings (CH1: Detection enabled)	
6	Warning output settings (CH2: Process alarm, CH3: Rate alarm)	
7	The CH2 process alarm limit values are written to the corresponding buffer memory addresses.	
8	CH3 rate alarm warning detection period (800 ms)	
9	The CH3 rate alarm limit values are written to the corresponding buffer memory addresses.	
10	CH1 input signal error detection setting value: 10%	
11	The operation condition setting request is turned ON.	
12	When the setting is completed, the operation condition setting request is turned OFF.	

Tab 6-3: Description of the program for the initial settings

● Communication with HART devices

The following part of the program is optional. If the HART devices are set and monitored with the tool MX CommDTM-HART, these instructions can be omitted.

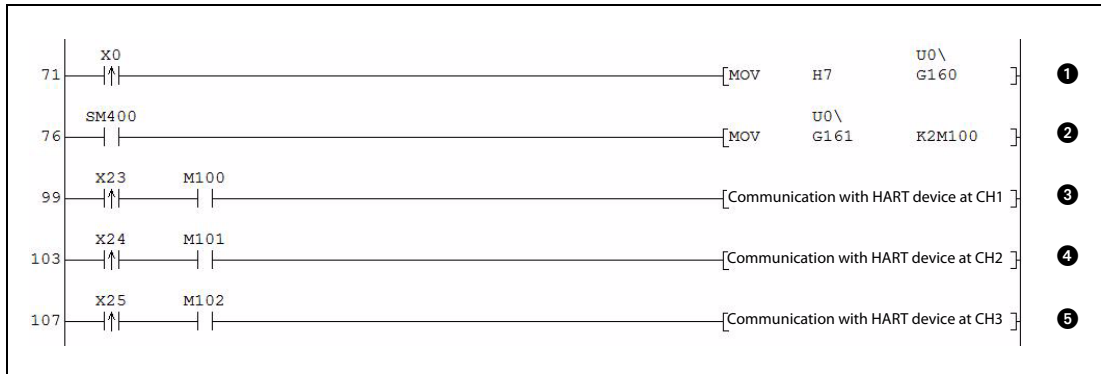

Fig. 6-7: Communication with HART devices

Number	Description	
①	HART enable/disable setting (CH1, CH2, CH3: HART enabled)	
②	The HART scan list is moved to the internal relays M100 to M107. Since SM400 is always ON, this MOV instruction is executed in every program cycle.	
③	Sending of commands to the HART device, reading of information received from the HART device etc.	CH1
④		CH2
⑤		CH3

Tab 6-4: Description of the program shown above

● Reading of digital output values

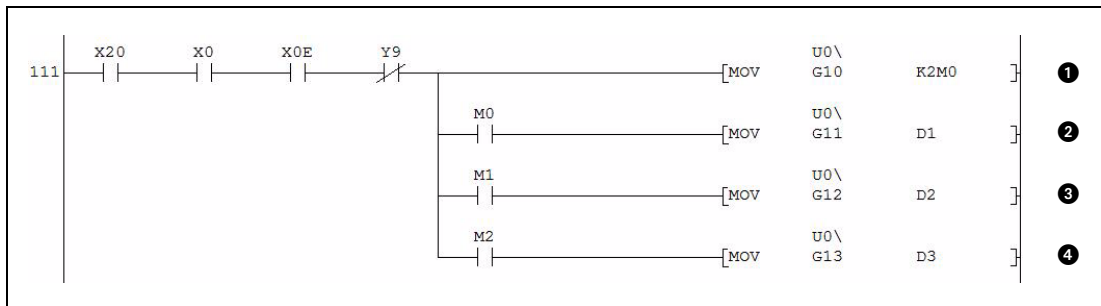

Fig. 6-8: Reading of the digital output values

Number	Description	
①	The A/D conversion completed flags are moved to the internal relays M0 to M7.	
②	When the conversion is completed the digital output value for each channel is read.	CH1
③		CH2
④		CH3

Tab 6-5: Description of the program shown above

● Warning (process alarm, rate alarm) occurrence status and processing at warning occurrence

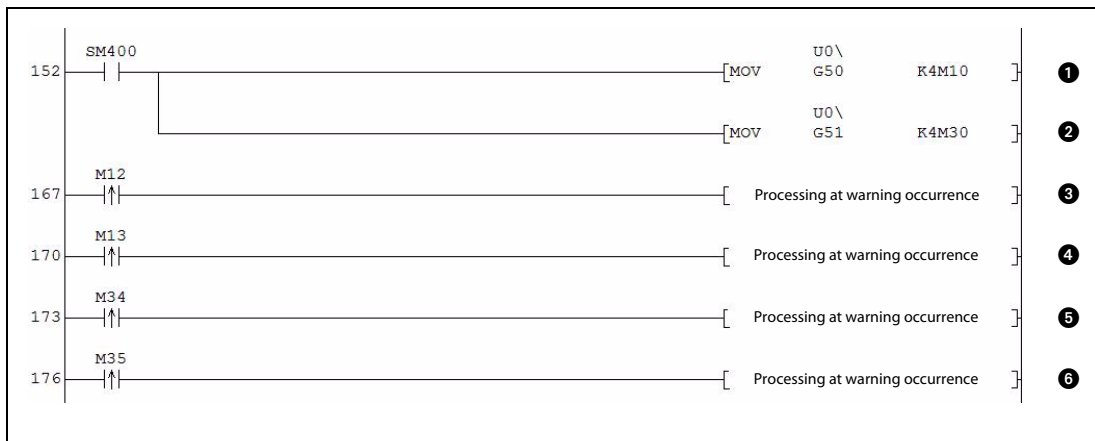

Fig. 6-9: For each warning separate instructions are executed

Number	Description	
①	The status of the warning output flags is moved to internal relays. Since SM400 is always ON, these MOV instructions are executed in every program cycle.	The warning output flags (process alarm) are moved to the internal relays M10 to M25.
②		The warning output flags (rate alarm) are moved to the internal relays M30 to M45.
③	Processing at warning occurrence	CH2 process alarm upper limit value warning
④		CH2 process alarm lower limit value warning
⑤		CH3 rate alarm upper limit value warning
⑥		CH3 rate alarm lower limit value warning

Tab 6-6: Description of the program shown above

● Error detection and display

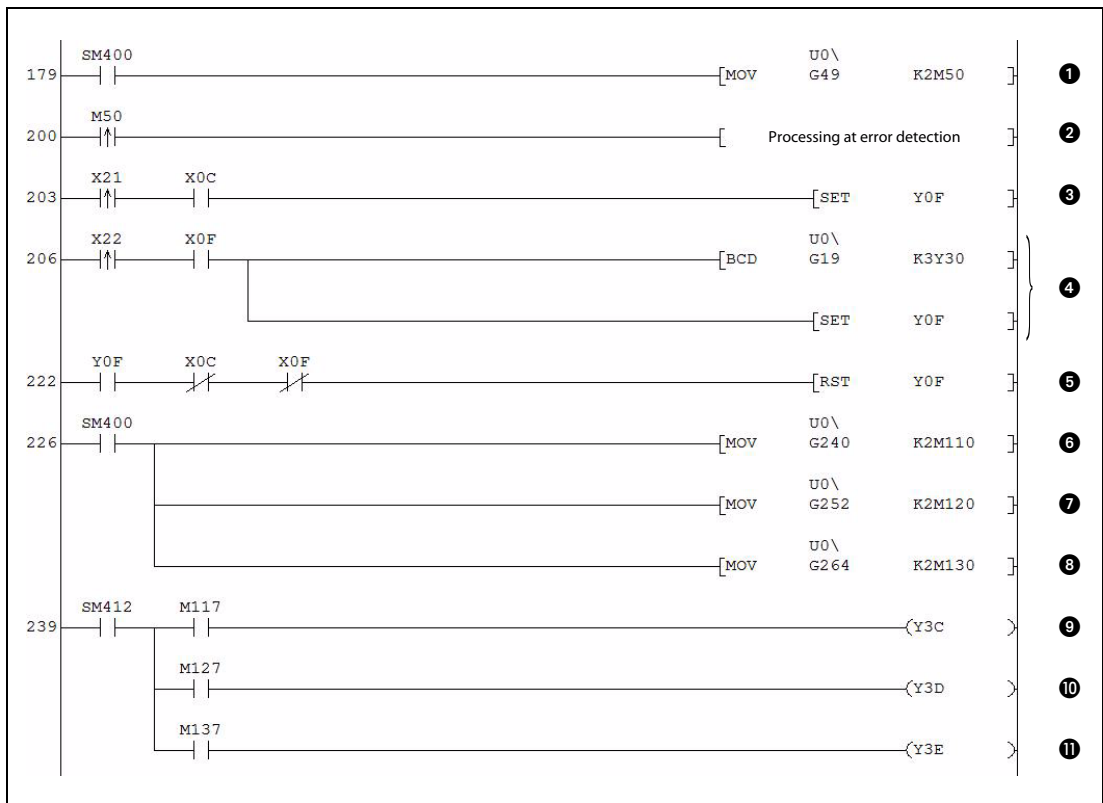

Fig. 6-10: Error detection and handling

Number	Description	
①	The input signal error detection flags are read. This MOV instruction is executed in every program cycle since SM400 is always ON.	
②	Processing for an input signal error at CH1.	
③	When an input error has been detected and the reset signal (X21) is ON, the error clear request (YF) is set.	
④	In case of an error the error code is output in BCD and the error clear request (YF) is set.	
⑤	When there is no error indicated, the error clear request (YF) is turned OFF.	
⑥	The HART field device status is read and stored in internal relays (SM400 is always ON).	Status of device connected to CH1
⑦		Status of device connected to CH2
⑧		Status of device connected to CH3
⑨	A malfunction of a HART field device is indicated by a flashing lamp. SM412 is a 1 second clock signal.	Device malfunction at CH1
⑩		Device malfunction at CH2
⑪		Device malfunction at CH3

Tab 6-7: Description of the program shown above

6.3 Example 2: ME1AD8HAI-Q used in Remote I/O Network

System configuration

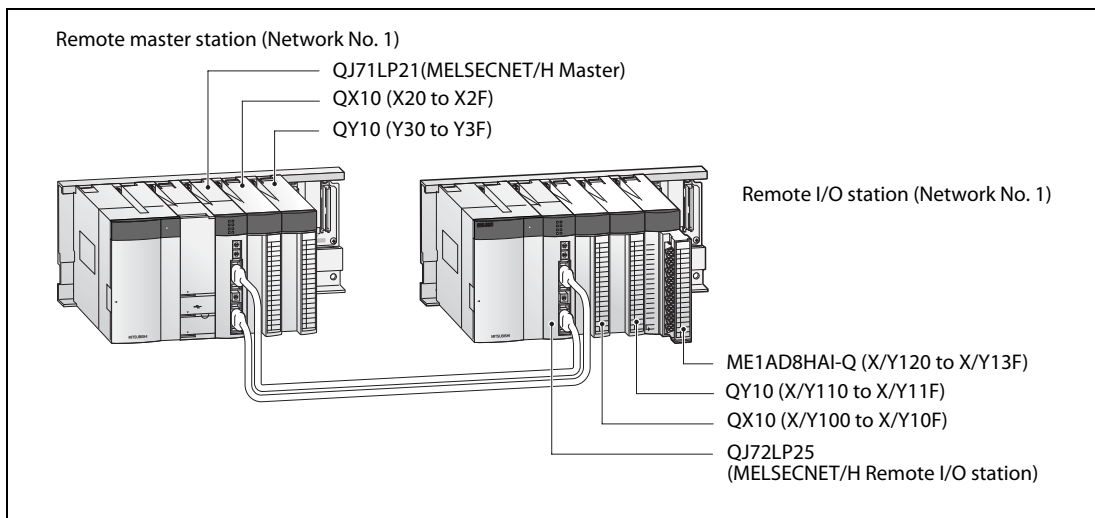

Fig. 6-11: For this example the ME1AD8HAI-Q is installed in a remote I/O station.

Channel	Input range setting
CH1 to CH3	4 to 20 mA
CH4 to CH8	not used

Tab 6-8: Conditions for the intelligent function module switch setting

Program conditions

- The following averaging processing specification is used for each channel.
 - CH1: Sampling processing
 - CH2: Time averaging (1000 ms)
 - CH3: Primary delay filtering (100 ms)
- CH1 uses the input signal error detection function (Refer to section 3.3.3)
 - Input signal error detection: 10 %
- CH2 uses the warning output setting (process alarm) (Refer to section 3.3.4.)
 - Process alarm upper upper limit value: 7000
 - Process alarm upper lower limit value: 6000
 - Process alarm lower upper limit value: 1500
 - Process alarm lower lower limit value: 1000
- CH3 uses the warning output setting (rate alarm) (Refer to section 3.3.4.)
 - Rate alarm warning detection period : 800 ms
 - Rate alarm upper limit value: 0.3 %
 - Rate alarm upper limit value: 0.1 %
- In the event of a write error, an error code is displayed in BCD format. The error code shall be reset after removal of the cause.
- If one of the HART devices is malfunctioning, error processing is performed.

6.3.1 Before creating a program

Before creating the program, perform the steps described in section 6.2.1.

List of devices

Device	Function	Remark		
Inputs (in main base unit)	X20	Digital output value read command input signal	QX10 (X20 to X2F)	
	X21	Input signal error detection reset signal		
	X22	Error reset signal		
	X23	CH1 HART device communication request		
	X24	CH2 HART device communication request		
	X25	CH3 HART device communication request		
Inputs (in remote I/O station)	X120	Module ready	ME1AD8HAI-Q (X120 to X13F)	
	X129	Operating condition setting completed flag		
	X12C	Input signal error detection signal		
	X12E	A/D conversion completed flag		
	X12F	Error flag		
Outputs (in main base unit)	Y30 to Y3B	Error code display (BCD 3 digits)	QY10 (Y30 to Y3F)	
Outputs (in remote I/O station)	Y129	Operating condition setting request	ME1AD8HAI-Q (Y120 to Y13F)	
	Y12F	Error clear request		
Internal relays	M200	REMTO instruction is completed normally	REMTO instruction for initial setting of the ME1AD8HAI-Q	
	M201	REMTO instruction is completed with an error		
	M300	REMFR instruction is completed normally	REMFR instruction for reading the HART scan list	
	M301	REMFR instruction is completed with an error		
	M310	REMFR instruction is completed normally	REMFR instruction for reading the digital values	
	M311	REMFR instruction is completed with an error		
	M320	REMFR instruction is completed normally	REMFR instruction for reading the input signal error status and the warnings	
	M321	REMFR instruction is completed with an error		
	M330	REMFR instruction is completed normally	REMFR instruction for reading the error code	
	M331	REMFR instruction is completed with an error		
	M340	REMFR instruction is completed normally	REMFR instruction for reading the status of HART field device connected to CH1	
	M341	REMFR instruction is completed with an error		
	M350	REMFR instruction is completed normally	REMFR instruction for reading the status of HART field device connected to CH2	
	M351	REMFR instruction is completed with an error		
	M360	REMFR instruction is completed normally	REMFR instruction for reading the status of HART field device connected to CH3	
	M361	REMFR instruction is completed with an error		
		M1000	Master control instruction for the processing concerning the ME1AD8HAI-Q	
		M1001	Initial setting of ME1AD8HAI-Q requested	
		M1002	Perform initial setting of ME1AD8HAI-Q	
		M1003	Initial setting of ME1AD8HAI-Q in progress/performed	
	M1004	Read A/D conversion flags and analog values of CH1 to CH3		
Link Devices	SB20	Module status		
	SB47	Baton pass status (host)	Link status of MELSECNET/H remote master station	
	SB49	Host data link status		
	SW70	Baton pass status of each station	Link status of MELSECNET/H remote I/O station (station No. 1)	
	SW74	Cyclic transmission status of each station		
	SW78	Parameter communication status of each station		
Timer	T100	Baton pass status	Delay for network communication errors.	
	T101	Data link status		
	T102	Baton pass status		
	T103	Cyclic transmission status		
	T104	Parameter communication status		

Tab 6-9: List of used devices

	Device	Function	Remark
Register	D1	CH1 Digital output value	
	D2	CH2 Digital output value	
	D3	CH3 Digital output value	
	D6	ME1AD8HAI-Q input signal error detection flags	
	D7, D8	Warning output flags	The warning output flags for all channels are stored in D7 (process alarms) and D8 (rate alarms).
	D9	ME1AD8HAI-Q error code	
	D10	A/D conversion completed flags CH1 to CH8	
	D11	CH1 Digital output value	Temporary storage for the digital values
	D12	CH2 Digital output value	
	D13	CH3 Digital output value	
	D100	HART scan list	D100.0 to D100.7 are set when a HART device is detected at the channels 1 to 8.
	D101	Status of HART field device connected to CH1	
	D102	Status of HART field device connected to CH2	
	D103	Status of HART field device connected to CH3	
	D1000 to D1160	Temporary storage for the parameters of the ME1AD8HAI-Q	D1000 -> Buffer memory address Un\G0, D1001 -> Un\G1, D1002 -> Un\G2 D1160 -> Un\G160

Tab 6-9: List of used devices

NOTE

For details on the MELSECNET/H remote I/O network, refer to the MELSECNET/H Network System Reference Manual (Remote I/O Network).

6.3.2 Network Parameter and Program

NOTE

The dedicated instructions used for reading/writing the buffer memory of the intelligent function module on a remote I/O station (REMTO and REMFR) are the execution type for which several scans are needed. Therefore, transmissions of the execution results are not synchronized with the I/O signal operations. When reading a digital output value on an analog input module after changing the operating condition during operation, be sure to read the A/D conversion completed flag (buffer memory address 10) at the same time.

Also, for the case of changing the operating condition, insert an interlock to prevent the execution of the REMFR instruction.

Network parameter setting

- Using the programming software, call up the **Network Parameter** selection box by double clicking on the highlighted option.

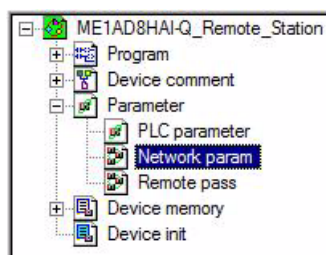

- When the box has been opened, select Ethernet/CCIE/MELSECNET.

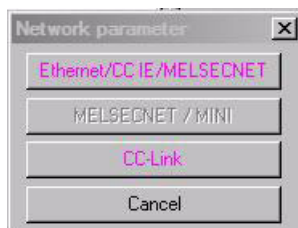

This opens up the dialogue box to allow the MELSECNET module to be configured which can be seen below.

- In the **Network type** window, click on the down arrow, to show the available selections.

	Module 1	Module 2	M
Network type	None	None	None
Starting I/O No.			
Network No.			
Total stations			
Group No.			
Station No.			
Mode			

- ④ Select **MNET/H (Remote-Master)** and enter the other items as shown below.

	Module 1	Module 2
Network type	MNET/H(Remote master)	None
Starting I/O No.	0000	
Network No.	1	
Total stations	1	
Group No.		
Station No.		
Mode	On line	
	Network range assignment	
	Refresh parameters	
	Interrupt settings	

The dialogue box now shows the specific setting options for the module. The buttons in the bottom half of the table that are in red are for setting the mandatory parts of the module, those in magenta are optional.

- ⑤ Click on **Network range assignment** and **Switch screens** to **XY setting**.

Network parameters Assignment the MNET/10(H) remote station network range. Module No.:

Setup common parameters and I/O assignments.

Assignment method
 Points/Start
 Start/End

Monitoring time X 10ms
 Total slave stations

Parameter name
 Switch screens

StationNo.	M station -> R station						M station		
	Y			Y			X		
	Points	Start	End	Points	Start	End	Points	Start	End
1									

- ⑥ Enter the following:

Start/End
 Total slave stations
 Switch screens

StationNo.	M station -> R station						M station <- R station					
	Y			Y			X			X		
	Points	Start	End	Points	Start	End	Points	Start	End	Points	Start	End
1	256	0100	01FF	256	0000	00FF	256	0100	01FF	256	0000	00FF

- ⑦ **Switch screens** to **BW setting** and enter the following:

Start/End
 Total slave stations
 Switch screens

StationNo.	M station -> R station			M station <- R station			M station -> R station			M station <- R station		
	B			B			W			W		
	Points	Start	End	Points	Start	End	Points	Start	End	Points	Start	End
1							256	0000	00FF	256	0100	01FF

- ⑧ When the settings have been made, click **End** to return to the main network parameter setting window. Note that the **Network range assignment** button has now changed to blue, indicating that changes have been made.

	Module 1	Module 2
Network type	MNET/H(Remote master)	None
Starting I/O No.	0000	
Network No.	1	
Total stations	1	
Group No.		
Station No.		
Mode	On line	
	Network range assignment	
	Refresh parameters	
	Interrupt settings	

- ⑨ Next, click on **Refresh parameters** to bring up the following dialogue. This is where the settings for the data exchange between MELSECNET/H and PLC CPU will be made. Enter the values shown below.

	Link side					PLC side			
	Dev. name	Points	Start	End		Dev. name	Points	Start	End
Transfer SB	SB	512	0000	01FF	↔	SB	512	0000	01FF
Transfer SW	SW	512	0000	01FF	↔	SW	512	0000	01FF
Random cyclic	LB				↔				
Random cyclic	LW				↔				
Transfer1	LB	8192	0000	1FFF	↔	B	8192	0000	1FFF
Transfer2	LW	8192	0000	1FFF	↔	W	8192	0000	1FFF
Transfer3	LX	512	0000	01FF	↔	X	512	0000	01FF
Transfer4	LY	512	0000	01FF	↔	Y	512	0000	01FF
Transfer5					↔				
Transfer6					↔				

- ⑩ When the settings have been made, click **End** to return to the main network parameter setting window.
- ⑪ Click **End** to check and close the main network parameter setting dialogue. These settings will be sent to the PLC next time the parameters are downloaded.

Program

- Remote I/O station status checking

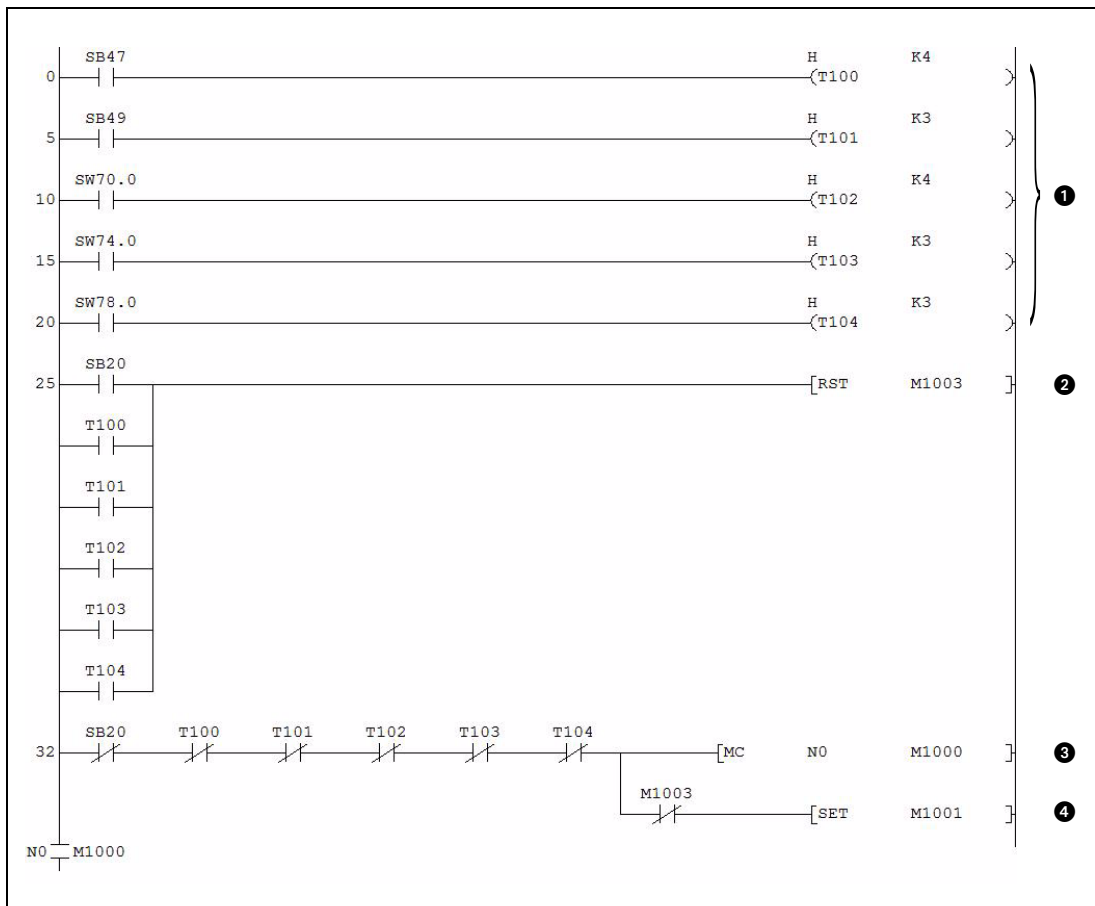

Fig. 6-12: Status checking of the remote I/O station

Number	Description
①	To prevent the control from stopping even if the network detects an instantaneous error due to a cable problem, noise or any other condition, the errors are delayed. Note that the above "4" and "3" represent standard values.
②	After the occurrence of a MELSECNET/H communication error, initial setting of the ME1AD8HAI-Q is required. M1003 (Initial setting of ME1AD8HAI-Q in progress/performed) is reset for preparation of the initial setting.
③	When the communication with the MELSECNET/H remote I/O station is without fault, the master control instruction is switched ON.
④	When the communication with the MELSECNET/H remote I/O station is possible and initial setting has not been performed already, the initial setting request (M1001) is set.

Tab 6-10: Description of the program shown above

NOTE

The following program for initial setting and processing of the ME1AD8HAI-Q will only be executed if the input condition of the master control instruction is set, i.e. M1000 is "1".

● Initial settings

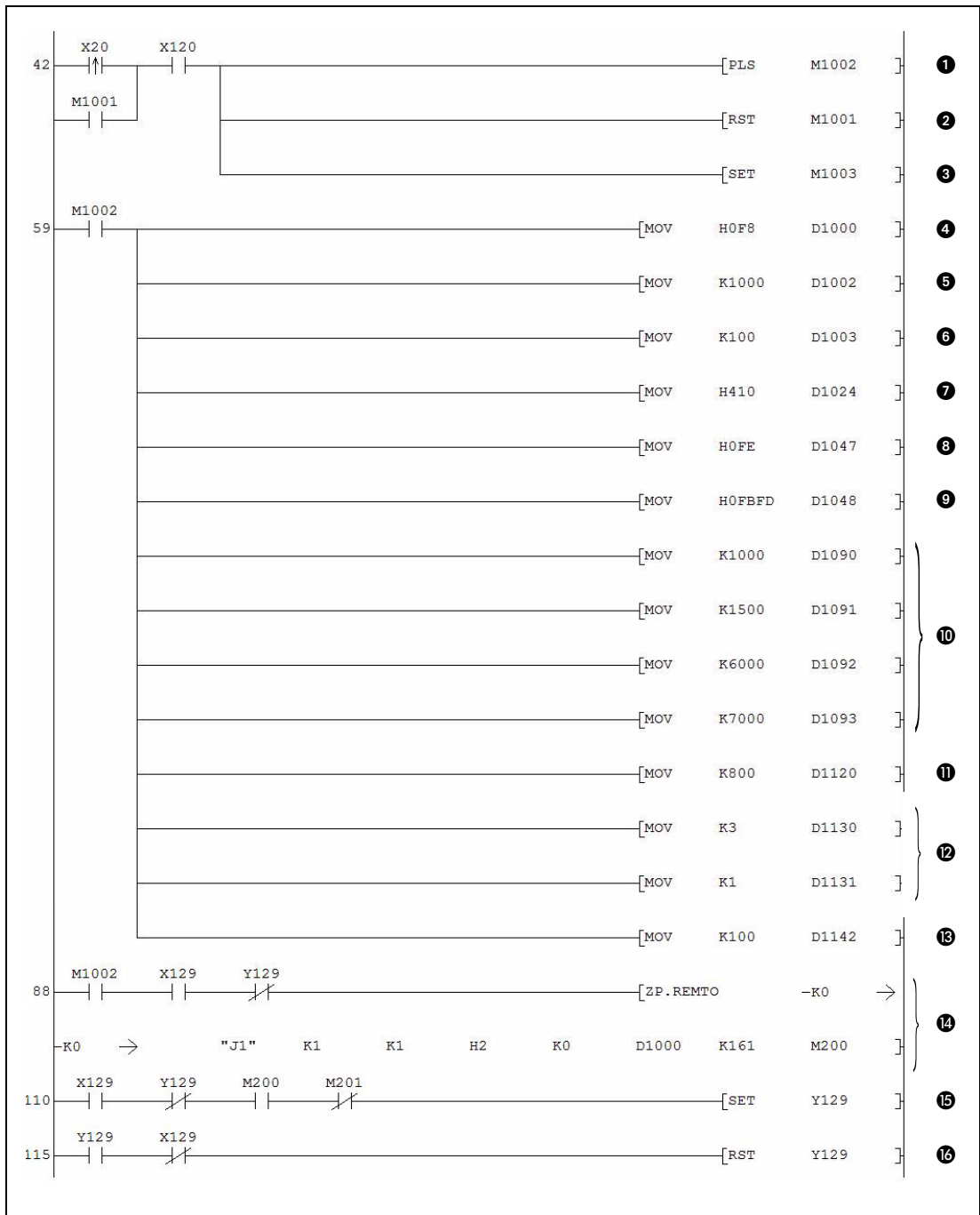

Fig. 6-13: Initial settings performed by the sequence program

Number	Description	
①	These three instructions are executed when a digital output read command (X20) or a request for initial setting of the ME1AD8HAI-Q (M1001) is issued.	Pulse: Perform initial setting
②		Initial setting request is reset
③		Initial setting in progress is set
④	A/D conversion enable/disable setting (CH1, CH2, CH3: enabled)	
⑤	Average time / Average number of times / Move average / Time constant settings	CH2: Time averaging (1000 ms)
⑥		CH3: Primary delay filtering (100 ms)
⑦	Averaging process specification (CH1: Sampling processing, CH2: Time averaging, CH3: Primary delay filtering)	

Tab 6-11: Description of the program shown above

Number	Description
8	Input signal error detection settings (CH1: Detection enabled)
9	Warning output settings (CH2: Process alarm, CH3: Rate alarm)
10	The CH2 process alarm limit values are written to the corresponding buffer memory addresses.
11	CH3 rate alarm warning detection period (800 ms)
12	The CH3 rate alarm limit values are written to the corresponding buffer memory addresses.
13	CH1 input signal error detection setting value: 10%
14	The parameters are written to the buffer memory of the ME1AD8HAI-Q
15	The operation condition setting request is turned ON.
16	When the setting is completed, the operation condition setting request is turned OFF.

Tab 6-11: Description of the program shown above

● Communication with HART devices

The following part of the program is optional. If the HART devices are set and monitored with the tool MX CommdTM-HART, these instructions can be omitted.

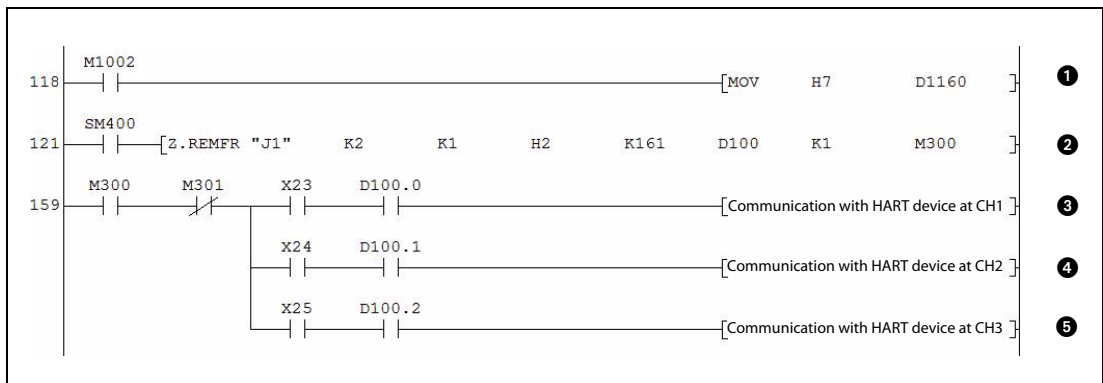

Fig. 6-14: Communication with HART devices

Number	Description	
1	HART enable/disable setting (CH1, CH2, CH3: HART enabled)	
2	The HART scan list is moved to the register D100. Since SM400 is always ON, this Z.REMFR instruction is executed in every program cycle.	
3	Sending of commands to the HART device, reading of information received from the HART device etc.	CH1
4		CH2
5		CH3

Tab 6-12: Description of the program shown above

● Reading of digital output values

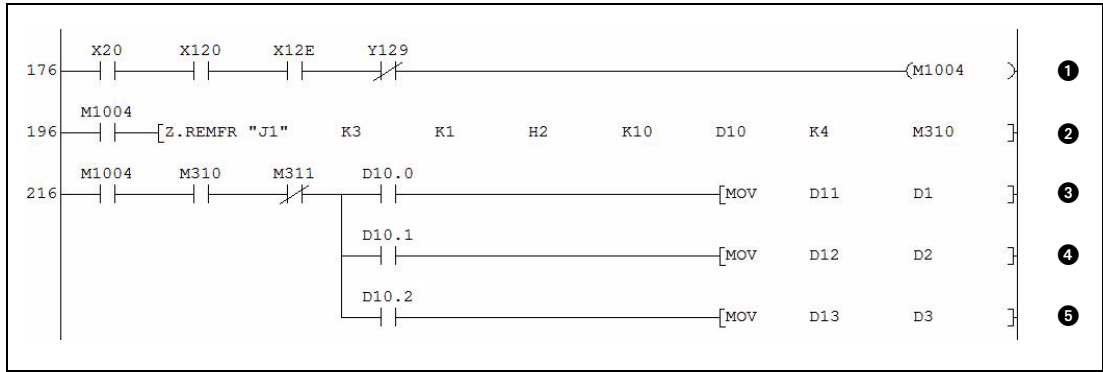

Fig. 6-15: Reading of the A/D conversion completed flags and the digital output values

Number	Description	
①	The digital output value read request is temporary stored in M1004.	
②	The A/D conversion completed flags and the CH1 to CH3 digital output values are moved into the registers D10 to D13.	
③	When the A/D conversion is completed the digital output values are moved to their final destinations.	CH1
④		CH2
⑤		CH3

Tab 6-13: Description of the program shown above

● Input signal error and warning (process alarm, rate alarm) occurrence status and processing at warning occurrence

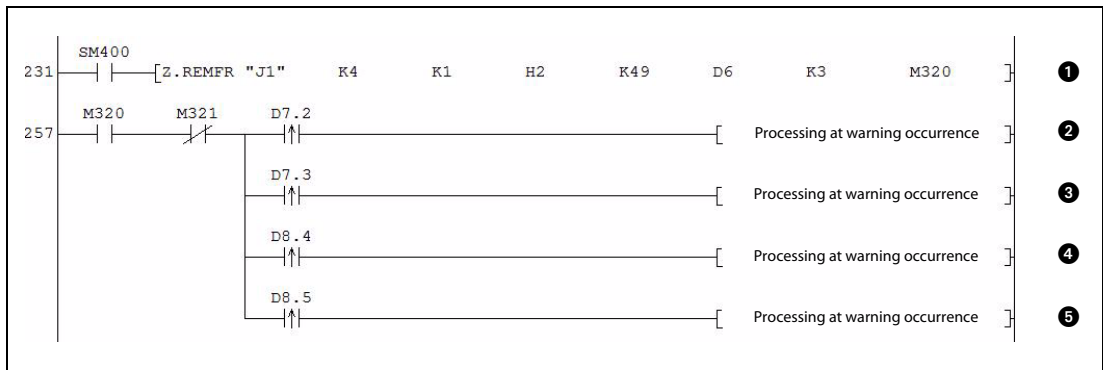

Fig. 6-16: For each warning separate instructions are executed

Number	Description	
①	In every program cycle (SM400 is always ON) the status of the input signal error flags and warning output flags is moved to the registers D6 resp. D7 and D8. (D6: input signal errors, D7: process alarms, D8: rate alarms).	
②	Processing at warning occurrence	CH2 process alarm upper limit value warning
③		CH2 process alarm lower limit value warning
④		CH3 rate alarm upper limit value warning
⑤		CH3 rate alarm lower limit value warning

Tab 6-14: Description of the above program

● Error detection and display

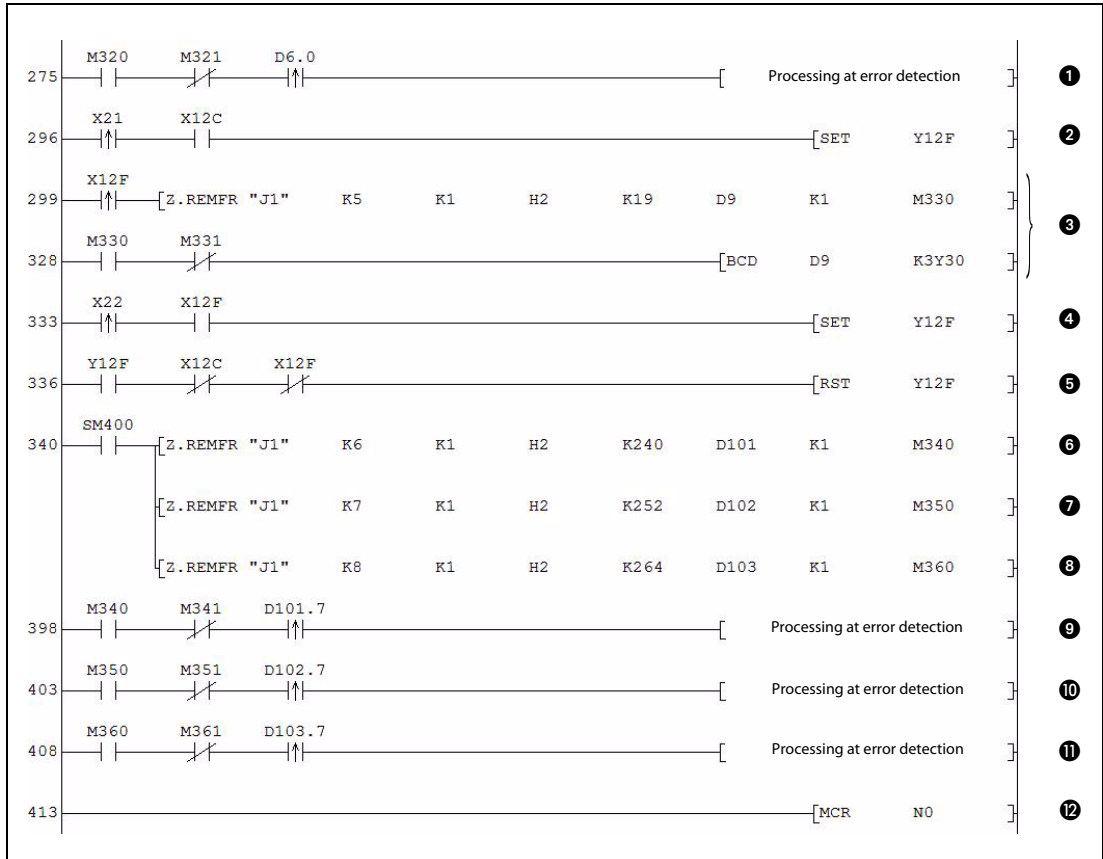

Fig. 6-17: Error detection and handling

Number	Description	
①	Processing for an input signal error at CH1. (The status of the input signal error flags has been read concurrently with the warnings (refer to fig. 6-16))	
②	When an input error has been detected and the reset signal (X21) is ON, the error clear request (Y12F) is set.	
③	In case of an error the error code is read and stored in D9. Then the error code is output in BCD.	
④	The error clear request (Y12F) is set.	
⑤	When there is no error indicated, the error clear request (Y12F) is turned OFF.	
⑥	The HART field device status is read and stored in internal relays (SM400 is always ON).	Status of device connected to CH1
⑦		Status of device connected to CH2
⑧		Status of device connected to CH3
⑨	Processing when a malfunction of a HART field device is detected.	Device malfunction at CH1
⑩		Device malfunction at CH2
⑪		Device malfunction at CH3
⑫	Master control reset (Only when the input condition for the MC instruction (fig. 6-13) is set, the instructions between the MC and the MCR instruction are executed.)	

Tab 6-15: Description of the error detection and handling

7 Troubleshooting

The following section explains the types of errors that may occur when the HART analog input module ME1AD8HAI-Q is used, and how to troubleshoot such errors.

7.1 Error Code List

If an error occurs in the analog input module while writing to or reading data from the programmable controller CPU, an error code is written to buffer memory address 19 (Un\G19).

Error code (decimal)	Error description	Corrective action
10□	The input range is set with an illegal value in the intelligent function module switch setting in the PLC parameter. □ indicates the channel number set incorrectly.	Set a correct parameter value in the parameter setting using GX Developer or GX IEC Developer. (Refer to section 4.5.)
111	Hardware error of the module.	Turn the power OFF and ON again. If the error occurs again, the module may be malfunctioning. Please consult your local Mitsubishi representative, explaining the detailed description of the problem.
112	The setting of the intelligent function module switch 5 is other than 0.	Set a correct parameter value in the parameter setting using GX Developer or GX IEC Developer. (Refer to section 4.5.)
13□*1	HART communication error. The device answer is erroneous or timed out. □ indicates the channel number.	<ul style="list-style-type: none"> Make sure the HART device's polling address is set to '0'. Check the connection to the HART device. Increase the "HART Maximum Retries" setting in the buffer memory. (Refer to section 3.5.24.)
14□*1	A/D converter faulty. The expected cycle time was exceeded. □ indicates the channel number.	Turn the power OFF and ON again. If the error occurs again, the module may be malfunctioning. Please consult your local Mitsubishi representative, explaining the detailed description of the problem.
20□*1	The averaging time set in Un\G1 to Un\G8 is outside the range of 320 to 5000 ms. □ indicates the channel number set incorrectly	Re-set the averaging time setting to within 320 to 5000 ms.
30□*1	The averaging count set in Un\G1 to Un\G8 is outside the range of 4 to 500 times. □ indicates the channel number set incorrectly.	Re-set the averaging count setting to within 4 to 500 times.
31□*1	The moving average count set in Un\G1 to Un\G8 is outside the range of 2 to 60 times. □ indicates the channel number set incorrectly.	Re-set the moving average count setting to within 2 to 60 times.
32□*1	The time constant for the primary delay filter set in Un\G1 to Un\G8 is outside the range of 80 to 5000. □ indicates the channel number set incorrectly.	Re-set the time constant setting to within 80 to 5000.
34□*1	In the CH□ rate alarm upper/lower limit value setting (Un\G126 to Un\G141), Lower limit ≥ Upper limit. □ indicates the channel number set incorrectly.	Re-set the CH□ rate alarm upper/lower limit value (Un\G126 to Un\G141) so that the lower limit value is smaller than the upper limit value.
6△□*1	The process alarm upper/lower limit value (Un\G86 to Un\G117) are set contradictorily. □ indicates the channel number set incorrectly. △ indicates the following state. 2: Lower lower limit value > lower upper limit value 3: Lower upper limit value > upper lower limit value 4: Upper lower limit value > upper upper limit value	Re-set the contents of the process alarm upper/lower limit values (Un\G86 to Un\G117).
70□*1	The rate alarm warning detection period (Un\G118 to Un\G125) is outside the range of 80 to 5000 ms. □ indicates the channel number set incorrectly.	Re-set the rate alarm warning detection period (Un\G118 to Un\G125) to within 80 to 5000 ms.

Tab. 7-1: Error code list

Error code (decimal)	Error description	Corrective action
71□*1	The rate alarm warning detection period (Un\G118 to Un\G125) is not: – A multiple of the sampling cycle or – A multiple of the time or count averaging conversion cycle. □ indicates the channel number set incorrectly.	Change the value of the rate alarm warning detection period as follows: – For sampling processing: A multiple of conversion cycle – For averaging processing: A multiple of time or count averaging conversion cycle
72□*1	When the time or count averaging setting in Un\G1 to Un\G8 is changed, the rate alarm warning detection period is not a multiple of the corresponding new time or count averaging conversion period. □ indicates the channel number set incorrectly.	Re-set the time averaging or count averaging setting so that the corresponding rate alarm warning detection period is a multiple of the time or count averaging conversion period.
80□*1	CH□ input signal error detection setting value (Un\G142 to Un\G149) is outside the range of 0 to 250. □ indicates the channel number set incorrectly.	Re-set the input signal error detection setting value to within 0 to 250.
90□*1	The scaling upper/lower limit value (Un\G62 to Un\G77) is set outside the range of -32000 to 32000. □ indicates the channel number set incorrectly.	Correct the scaling upper/lower limit value within the range of -32000 to 32000.
91□*1	In the scaling upper/lower limit value setting (Un\G62 to Un\G77), Lower limit ≥ Upper limit. □ indicates the channel number set incorrectly.	Set them again so that the scaling upper limit value is greater than the scaling lower limit value.

Tab. 7-1: Error code list

NOTES

When two or more errors have occurred, the latest error found by the analog input module is stored.

An error described with *1 can be cleared by turning ON the error clear request (YF).

7.2 Troubleshooting using the LEDs of the Module

7.2.1 When the "RUN" LED is flashing or turned off

Check item	Corrective action
Is the intelligent function module setting switch 4 set to "other than 0"?	Using GX Developer or GX IEC Developer parameter setting, set intelligent function module setting switch 4 to "0" (Refer to section 4.5).

Tab. 7-2: When the "RUN" LED is flashing

Check item	Corrective action
Is the power being supplied?	Confirm that the supply voltage for the power supply module is within the rated range.
Is the capacity of the power supply module adequate?	Calculate the current consumption of the CPU module, I/O modules and intelligent function modules mounted on the base unit to see if the power supply capacity is adequate.
Has a watchdog timer error occurred?	Reset the programmable controller CPU and verify that it is lit. If the RUN LED does not light even after doing this, the module may be malfunctioning. Please consult your local Mitsubishi representative, explaining the detailed description of the problem.
Is the module correctly mounted on the base unit?	Check the mounting condition of the module.

Tab. 7-3: When the "RUN" LED is off

7.2.2 When the "ERR." LED is on or flashing

Check item	Corrective action
Is an error being generated?	Confirm the error code and take corrective action described in section 7.1.

Tab. 7-4: When the "ERR" LED is on

Check item	Corrective action
Is the intelligent function module setting switch 5 set to "other than 0"?	Using GX Developer or GX IEC Developer parameter setting, set intelligent function module setting switch 5 to "0" (Refer to section 4.5).

Tab. 7-5: When the "ERR" LED is flashing

7.2.3 When the "ALM" LED is on or flashing

Check item	Corrective action
Is a warning output being generated?	Check the warning output flag (Un\G50, Un\G51).

Tab. 7-6: When the "ALM" LED is on

Check item	Corrective action
Is an input signal error being generated?	Check the input signal error detection flag (Un\G49).

Tab. 7-7: When the "ALM" LED is flashing

7.3 When the digital output values cannot be read

Check item	Corrective action
Is 24 V DC external supply power being supplied?	Check that the external supply power terminals (terminals 17 (+24 V DC) and 18 (0V)) are supplied with a 24 V DC voltage.
Is there any fault with the analog signal lines such as disconnection or wire break?	Check for faulty condition of the signal lines by a visual check and a continuity check.
Is the CPU module in the STOP status?	Set the CPU module to the RUN status.
Is the digital output value at 4 (or 0) mA and 20 mA correct?	If the digital output values for the limits of the input range are not correct, the module may be malfunctioning. Please consult your local Mitsubishi representative, explaining the detailed description of the problem.
Is the input range setting correct?	Check the Un\G20, Un\G21 in the monitor of GX Developer or GX IEC Developer. If the input range setting is incorrect, redo the GX (IEC) Developer intelligent function module switch setting (Refer to section 4.5).
Is the A/D conversion enable/disable setting for the channel to be used set to A/D conversion disabled?	Check the ON/OFF status with Un\G0 in GX (IEC) Developer monitor and review the initial setting of the sequence program (Refer to section 3.5).
Has the operating condition setting request (Y9) been executed?	From GX Developer or GX IEC Developer, turn the operating condition setting request (Y9) from ON to OFF to check that the digital output values are stored into the Un\G11 to Un\G18. If so, review the initial setting of the sequence program (Refer to section 3.4.)
Is the value set for the averaging processing specification correct?	<ul style="list-style-type: none"> • Time averaging: 320 to 5000 [ms] • Count averaging: 4 to 500 [times] • Moving averaging: 2 to 60 [times] • Primary delay filter: 80 to 5000 [ms] If the above requirements are not met, 0 is stored as a digital output value.
Is the voltage of the external power supply enough for correct operation of the analog transmitter?	<ul style="list-style-type: none"> • Check how much voltage can be supplied to the analog transmitter. If it is not enough for the analog transmitter, increase the voltage of the external power supply (maximum 28.8 V).

Tab. 7-8: Troubleshooting when the digital output values cannot be read

NOTE

The module may be faulty if the digital output values cannot be read after proper corrective actions have been taken according to the above check items. Please consult your local Mitsubishi representative, explaining the detailed description of the problem.

7.3.1 When A/D conversion completed flag does not turn ON

Check item	Corrective action
Is 24 V DC external supply power being supplied?	Check that the external supply power terminals (terminals 17 (+24 V DC) and 18 (0V)) are supplied with a 24 V DC voltage.
Is an input signal error being generated?	Check the input signal error detection flag (Un\G49).

Tab. 7-9: Troubleshooting when the A/D conversion completed flag does not turn ON

7.4 Checking the Analog Input Module Status

When the analog input module detail information is selected in GX Developer or GX IEC Developer system monitor, an error code and the status of the intelligent function module switch setting can be checked.

- Operating GX Developer
In the **Diagnostics** menu select **System monitor**.
- Operating GX IEC Developer
In the **Debug** menu select **System monitor**.

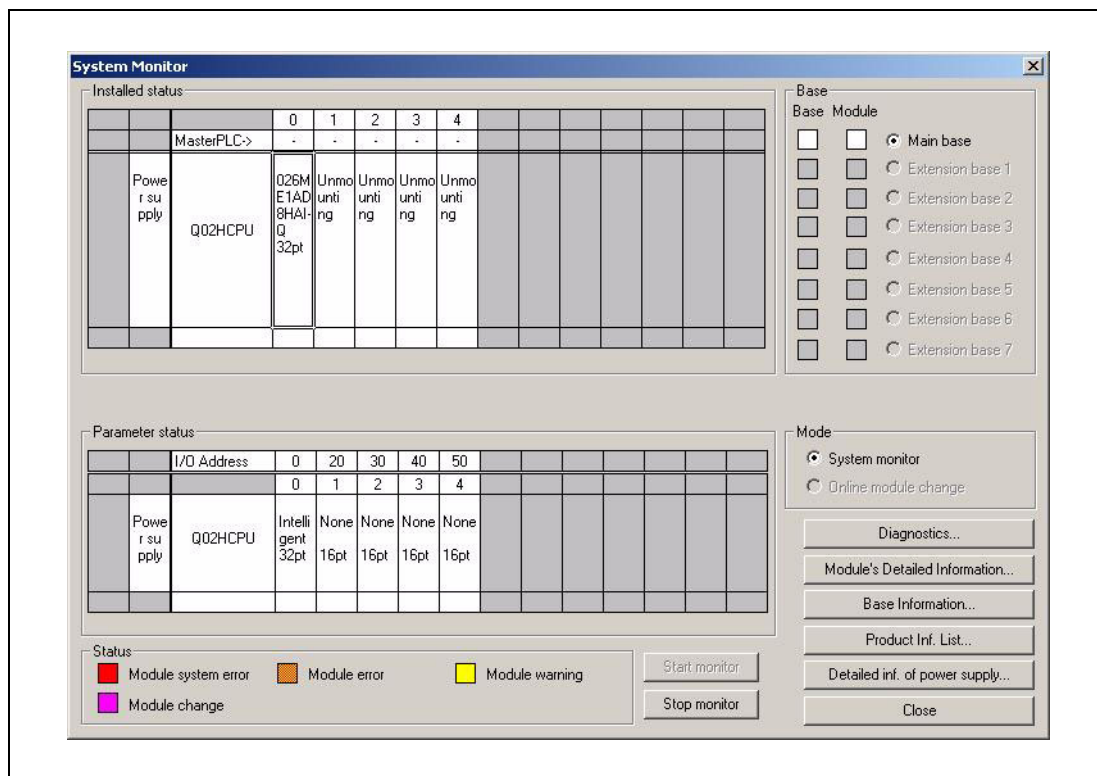

Fig. 7-1: The System Monitor displays comprehensive information of the connected PLC

For further information about a module, click on the module and then click **Module Detailed Information**.

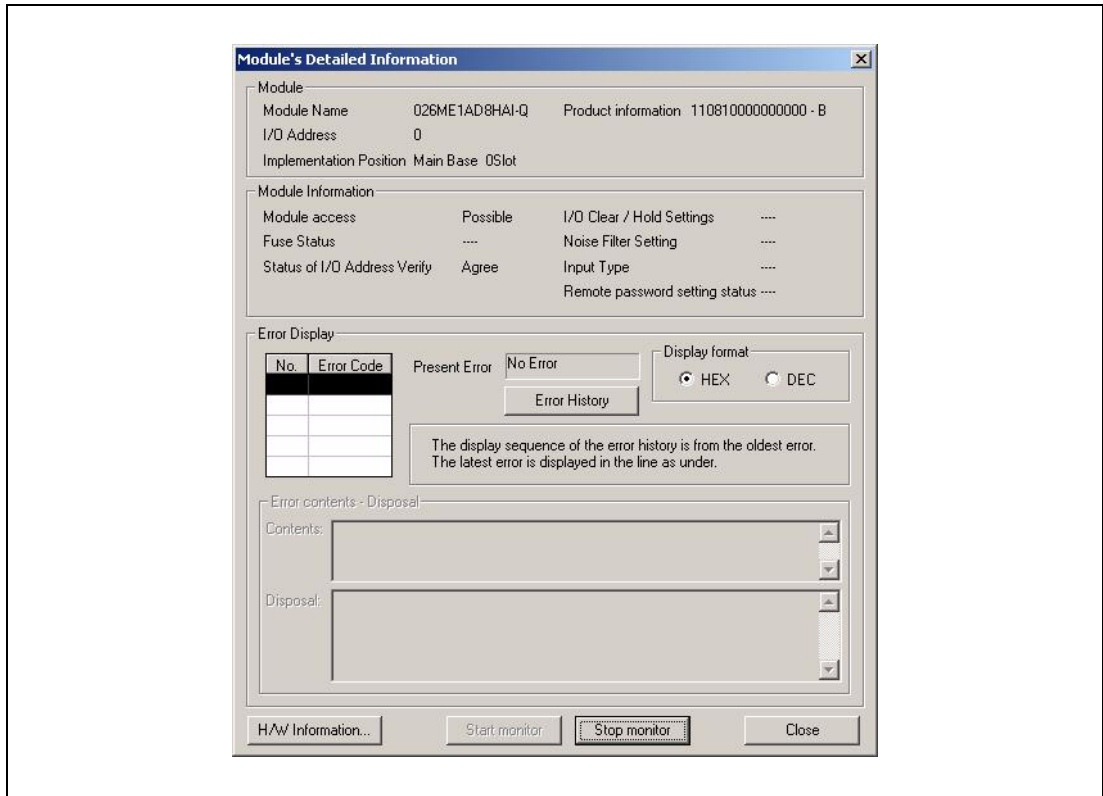

Fig. 7-2: Detailed information on the selected module allow an easy and quick troubleshooting

Contents of Module Detail Information

- **Module**
 - Module Name: Shows the designation of the module, e.g. ME1AD8HAI-Q
 - I/O Address: Head address of the module
 - Implementation Position: Shows whether the module is mounted to the main base or to an extension base and the position of the module.
 - Product information: Serial No. of the module. The letter shows the function version.
- **Module Information**
 - Module access: Shows whether the module is ready or not.
 - Fuse status: Not relevant for the HART analog input module ME1AD8HAI-Q.
 - Status of I/O Address Verify: Indicates whether the parameter set module and the installed module are identical.
 - I/O Clear / Hold Settings, Noise Filter Setting, etc.: Not relevant for the ME1AD8HAI-Q.
- **Error Display**
 - Checking the error code
The error code stored in buffer memory address 19 (Un\G19) of the ME1AD8HAI-Q is displayed in the **Present Error** field.
 - When the **Error History** button is pressed, the contents displayed in the **Present Error** field is displayed in the No. 1 field.

Index

Numerics		F	
2-wire transmitter	4-7	Function version	2-3
4-wire transmitter	4-7	G	
A		GX Works2	
A/D conversion		Auto refresh	5-7
Completed flag (buffer memory)	3-41	New intelligent function module	5-1
Completed flag (input signal)	3-21	Parameter setting for intelligent	
Enable/disable setting	3-40	function modules	5-5
Setting range	3-42	Setting switches for intelligent	
Accuracy	3-4	function modules	5-3
ALM LED	7-3	H	
Auto refresh	5-7	HART	
Average number of times setting	3-40	Command request	3-57
Average time setting	3-40	Date	3-63
Averaging process specification	3-43	Descriptor	3-60
B		Device Function Flags	3-62
Buffer memory		Device ID	3-61
Overview	3-24	Device Profile	3-62
Structure	3-23	Device Type	3-61
C		Device variables access flag (input signal)	3-19
Count averaging		Device variables access request	
Average number of times setting	3-40	(output signal)	3-22
Overview	3-7	Final Assembly Number	3-63
Current input characteristics	3-4	Long Tag	3-62
D		Manufacturer ID	3-60
Digital output value		Message	3-60
Storage in buffer memory	3-41	Private Label Distributor	3-62
E		PV Damping Value	3-64
Enable/disable setting		PV Range Unit Code	3-63
A/D conversion	3-40	PV Upper and Lower Range Value	3-64
HART communication	3-51	Revisions	3-61
Process alarm	3-45	Tag	3-60
Rate alarm	3-45	Transfer Function	3-64
Scaling function	3-47	Unit Code	3-64
Warning output	3-45	Write Protect	3-63
ERR. LED	7-3		
Error clear request (output signal)	3-22		
Error code list	7-1		
Error flag (input signal)	3-22		

HART Command	
Answer Channel	3-59
Answer Code	3-59
Answer Data	3-59
Answer Data Size	3-59
Answer Flag	3-59
Request Channel	3-58
Request Code	3-58
Request Data	3-58
Request Data Size	3-58
Request Flag	3-57
HART function	
Applicable cables	4-4
Command answer	3-59
Communication enable/disable setting	3-51
Device variable status	3-55
Extended field device status	3-54
Field device status	3-53
Information about HART devices	3-60
Process variables	3-56
Scan list	3-51
Write data error code	3-42
HART Master function	3-16

I

Input signal	
A/D conversion completed	3-21
Error flag	3-22
HART device variables access flag	3-19
Maximum/minimum value reset completed	3-21
Module ready	3-19
Operating condition setting completed	3-20
Warning	3-19
Input signal error detection	
Flags in buffer memory	3-46
Input	3-21
Overview	3-10
Setting	3-44
Setting value	3-50
Input voltage	4-5
Intelligent function module parameter setting	4-9
Intelligent function module switches	
Setting in GX Works2	5-3
setting in PLC parameter	4-10

L

LEDs	
ALM	7-3
ERR.	7-3
Overview	3-1
RUN	7-3

M

Maximum value hold function	3-9
Maximum/minimum value	
Reset completed flag	3-21
Reset request (output signal)	3-22
Storage area	3-44
ME1AD8HAI-Q	
Accuracy	3-4
Dimensions	3-5
I/O assignment	4-9
I/O characteristics	3-4
Installation	4-3
Intelligent function module switch settings	4-10
LEDs	3-1
Parameter setting	4-9
Specifications	3-3
MELSEC System Q CPU modules	2-1
MELSECNET/H remote I/O station	2-2
Minimum value hold function	3-9
Module ready (input signal)	3-19
Moving average	
Overview	3-7
Setting	3-40
Multiple CPU system	2-2
MX CommDTM-HART	4-11

N

Noise filter	4-8
--------------------	-----

O

Online module change	2-2
Operating condition	
Setting completed flag	3-20
Setting request (output signal)	3-22
Output signal	
Error clear request	3-22
HART device variables access request	3-22
Maximum/minimum value reset request	3-22
Operating condition setting request	3-22

P

Primary delay filter	
Overview	3-8
Time constant setting	3-40
Process alarm	
Overview	3-11
Upper/lower limit value	3-48
Warning output signal	3-19

R

Rate alarm	
Overview	3-12
Upper/lower limit value	3-50
Warning detection period	3-49
RUN LED	7-3

S

Sampling processing	3-7
Scaling function	
Enable/disable settings	3-47
Overview	3-15
Scaling value storage area	3-48
Upper /lower limit value	3-48
Setting range	3-42
Switch settings for intelligent function module ...	4-10
System monitor	7-5

T

Time averaging	
Overview	3-7
Setting	3-40
Troubleshooting	7-3

U

Upper/lower limit value	
Process alarm	3-48
Rate alarm	3-50
Scaling function	3-48

W

Warning output	
Enable/disable settings	3-45
Flags in buffer memory	3-47
Overview	3-11
Wiring	
2-wire transmitter	4-7
4-wire transmitter	4-7

HEADQUARTERS

MITSUBISHI ELECTRIC EUROPE B.V. **EUROPE**
 German Branch
 Gothaer Straße 8
D-40880 Ratingen
 Phone: +49 (0)2102 / 486-0
 Fax: +49 (0)2102 / 486-1120

MITSUBISHI ELECTRIC EUROPE B.V.-org.sl. **CZECH REP.**
 Czech Branch
 Avenir Business Park, Radlická 714/113a
CZ-158 00 Praha 5
 Phone: +420 - 251 551 470
 Fax: +420 - 251-551-471

MITSUBISHI ELECTRIC EUROPE B.V. **FRANCE**
 French Branch
 25, Boulevard des Bouvets
F-92741 Nanterre Cedex
 Phone: +33 (0)1 / 55 68 55 68
 Fax: +33 (0)1 / 55 68 57 57

MITSUBISHI ELECTRIC EUROPE B.V. **IRELAND**
 Irish Branch
 Westgate Business Park, Ballymount
IRL-Dublin 24
 Phone: +353 (0)1 4198800
 Fax: +353 (0)1 4198890

MITSUBISHI ELECTRIC EUROPE B.V. **ITALY**
 Italian Branch
 Viale Colleoni 7
I-20041 Agrate Brianza (MB)
 Phone: +39 039 / 60 53 1
 Fax: +39 039 / 60 53 312

MITSUBISHI ELECTRIC EUROPE B.V. **POLAND**
 Poland Branch
 Krakowska 50
PL-32-083 Balice
 Phone: +48 (0)12 / 630 47 00
 Fax: +48 (0)12 / 630 47 01

MITSUBISHI ELECTRIC EUROPE B.V. **RUSSIA**
 52, bid. 3 Kosmodamiyanskaya nab 8 floor
RU-115054 Moscow
 Phone: +7 495 721-2070
 Fax: +7 495 721-2071

MITSUBISHI ELECTRIC EUROPE B.V. **SPAIN**
 Spanish Branch
 Carretera de Rubí 76-80
E-08190 Sant Cugat del Vallés (Barcelona)
 Phone: 902 131121 // +34 935653131
 Fax: +34 935891579

MITSUBISHI ELECTRIC EUROPE B.V. **UK**
 UK Branch
 Travellers Lane
UK-Hatfield, Herts. AL10 8XB
 Phone: +44 (0)1707 / 27 61 00
 Fax: +44 (0)1707 / 27 86 95

MITSUBISHI ELECTRIC CORPORATION **JAPAN**
 Office Tower "Z" 14 F
 8-12,1 chome, Harumi Chuo-Ku
Tokyo 104-6212
 Phone: +81 3 622 160 60
 Fax: +81 3 622 160 75

MITSUBISHI ELECTRIC AUTOMATION, Inc. **USA**
 500 Corporate Woods Parkway
Vernon Hills, IL 60061
 Phone: +1 847 478 21 00
 Fax: +1 847 478 22 53

EUROPEAN REPRESENTATIVES

GEVA **AUSTRIA**
 Wiener Straße 89
AT-2500 Baden
 Phone: +43 (0)2252 / 85 55 20
 Fax: +43 (0)2252 / 488 60

TECHNIKON **BELARUS**
 Oktyabrskaya 19, Off. 705
BY-220030 Minsk
 Phone: +375 (0)17 / 210 46 26
 Fax: +375 (0)17 / 210 46 26

ESCO DRIVES & AUTOMATION **BELGIUM**
 Culliganlaan 3
BE-1831 Diegem
 Phone: +32 (0)2 / 717 64 30
 Fax: +32 (0)2 / 717 64 31

Koning & Hartman b.v. **BELGIUM**
 Woluwelaan 31
BE-1800 Vilvoorde
 Phone: +32 (0)2 / 257 02 40
 Fax: +32 (0)2 / 257 02 49

INEA RBT d.o.o. **BOSNIA AND HERZEGOVINA**
 Aleja Lipa 56
BA-71000 Sarajevo
 Phone: +387 (0)33 / 921 164
 Fax: +387 (0)33 / 524 539

AKHNATON **BULGARIA**
 4, Andrei Ljapchev Blvd., PO Box 21
BG-1756 Sofia
 Phone: +359 (0)2 / 817 6000
 Fax: +359 (0)2 / 97 44 06 1

INEA RBT d.o.o. **CROATIA**
 Losinjska 4 a
HR-10000 Zagreb
 Phone: +385 (0)1 / 36 940 -01 / -02 / -03
 Fax: +385 (0)1 / 36 940 -03

AutoCont C.S. s.r.o. **CZECH REPUBLIC**
 Technologická 374/6
CZ-708 00 Ostrava-Pustkovec
 Phone: +420 595 691 150
 Fax: +420 595 691 199

Beijer Electronics A/S **DENMARK**
 Lykkegårdsvej 17
DK-4000 Roskilde
 Phone: +45 (0)46 / 75 76 66
 Fax: +45 (0)46 / 75 56 26

Beijer Electronics Eesti OÜ **ESTONIA**
 Pärnu mnt.160i
EE-11317 Tallinn
 Phone: +372 (0)6 / 51 81 40
 Fax: +372 (0)6 / 51 81 49

Beijer Electronics OY **FINLAND**
 Peltoie 37
FIN-28400 Ulvila
 Phone: +358 (0)207 / 463 540
 Fax: +358 (0)207 / 463 541

UTEKO **GREECE**
 5, Mavrogenous Str.
GR-18542 Piraeus
 Phone: +30 211 / 1206 900
 Fax: +30 211 / 1206 999

MELTRADE Kft. **HUNGARY**
 Fertő utca 14.
HU-1107 Budapest
 Phone: +36 (0)1 / 431-9726
 Fax: +36 (0)1 / 431-9727

Beijer Electronics SIA **LATVIA**
 Ritausmas iela 23
LV-1058 Riga
 Phone: +371 (0)784 / 2280
 Fax: +371 (0)784 / 2281

Beijer Electronics UAB **LITHUANIA**
 Savanoriu Pr. 187
LT-02300 Vilnius
 Phone: +370 (0)5 / 232 3101
 Fax: +370 (0)5 / 232 2980

EUROPEAN REPRESENTATIVES

ALFATRADE Ltd. **MALTA**
 99, Paola Hill
Malta- Paola PLA 1702
 Phone: +356 (0)21 / 697 816
 Fax: +356 (0)21 / 697 817

INTEHSIS srl **MOLDOVA**
 bld. Traian 23/1
MD-2060 Kishinev
 Phone: +373 (0)22 / 66 4242
 Fax: +373 (0)22 / 66 4280

HIFLEX AUTOM.TECHNIEK B.V. **NETHERLANDS**
 Wolweverstraat 22
NL-2984 CD Ridderkerk
 Phone: +31 (0)180 - 46 60 04
 Fax: +31 (0)180 - 44 23 55

Koning & Hartman b.v. **NETHERLANDS**
 Haarlerbergweg 21-23
NL-1101 CH Amsterdam
 Phone: +31 (0)20 / 587 76 00
 Fax: +31 (0)20 / 587 76 05

Beijer Electronics AS **NORWAY**
 Postboks 487
NO-3002 Drammen
 Phone: +47 (0)32 / 24 30 00
 Fax: +47 (0)32 / 84 85 77

Fonseca S.A. **PORTUGAL**
 R. João Francisco do Casal 87/89
PT - 3801-997 Aveiro, Esgueira
 Phone: +351 (0)234 / 303 900
 Fax: +351 (0)234 / 303 910

Sirius Trading & Services srl **ROMANIA**
 R. 3
RO-060841 Bucuresti, Sector 6
 Phone: +40 (0)21 / 430 40 06
 Fax: +40 (0)21 / 430 40 02

INEA RBT d.o.o. **SERBIA**
 Izletnicka 10
SER-113000 Smederevo
 Phone: +381 (0)26 / 615 401
 Fax: +381 (0)26 / 615 401

SIMAP s.r.o. **SLOVAKIA**
 Jána Derku 1671
SK-911 01 Trenčín
 Phone: +421 (0)32 743 04 72
 Fax: +421 (0)32 743 75 20

PROCONT, spol. s r.o. Prešov **SLOVAKIA**
 Kúpeľná 1/A
SK-080 01 Prešov
 Phone: +421 (0)51 7580 611
 Fax: +421 (0)51 7580 650

INEA RBT d.o.o. **SLOVENIA**
 Stegne 11
SI-1000 Ljubljana
 Phone: +386 (0)1 / 513 8116
 Fax: +386 (0)1 / 513 8170

Beijer Electronics AB **SWEDEN**
 Box 426
SE-20124 Malmö
 Phone: +46 (0)40 / 35 86 00
 Fax: +46 (0)40 / 93 23 01

Omni Ray AG **SWITZERLAND**
 Im Schörl 5
CH-8600 Dübendorf
 Phone: +41 (0)44 / 802 28 80
 Fax: +41 (0)44 / 802 28 28

GTS **TURKEY**
 Bayraktar Bulvarı Nutuk Sok. No:5
TR-34775 Yukarı Dudullu-Ümraniye-İSTANBUL
 Phone: +90 (0)216 526 39 90
 Fax: +90 (0)216 526 3995

CSC Automation Ltd. **UKRAINE**
 4-B, M. Raskovoyi St.
UA-02660 Kiev
 Phone: +380 (0)44 / 494 33 55
 Fax: +380 (0)44 / 494-33-66

EURASIAN REPRESENTATIVES

TOO Kazpromavtomatika **KAZAKHSTAN**
 Ul. Zhambyla 28
KAZ-100017 Karaganda
 Phone: +7 7212 / 50 10 00
 Fax: +7 7212 / 50 11 50

MIDDLE EAST REPRESENTATIVES

I.C. SYSTEMS LTD. **EGYPT**
 23 Al-Saad-Al-Alee St.
EG-Sarayut, Maadi, Cairo
 Phone: +20 (0) 2 / 235 98 548
 Fax: +20 (0) 2 / 235 96 625

ILAN & GAVISH Ltd. **ISRAEL**
 24 Shenkar St., Kiryat Arie
IL-49001 Petah-Tiqva
 Phone: +972 (0)3 / 922 18 24
 Fax: +972 (0)3 / 924 0761

GIRIT CELADON LTD **ISRAEL**
 12 H'aomanut Street
IL-42505 Netanya
 Phone: +972 (0)9 / 863 39 80
 Fax: +972 (0)9 / 885 24 30

CEG INTERNATIONAL **LEBANON**
 Cebaco Center/Block A Autostrade DORA
Lebanon - Beirut
 Phone: +961 (0)1 / 240 430
 Fax: +961 (0)1 / 240 438

AFRICAN REPRESENTATIVE

CBI Ltd. **SOUTH AFRICA**
 Private Bag 2016
ZA-1600 Isando
 Phone: +27 (0)11 / 977 0770
 Fax: +27 (0)11 / 977 0761